

ars et labor



IN UNA PICCOLA BORGATA
MARINARA DI PALERMO
IL TEMPO SEMBRA ESSERSI FERMATO.
DA OLTRE CENTO ANNI,
CON LA PAZIENZA E LA CURA DI SEMPRE,
SI MISCELANO COLORI MEDITERRANEI
E POLVERI DI MARMO,
SI RECUPERANO ANTICHI DECORI
E SE NE CREANO DI NUOVI.
SI PROVANO SEMPRE NUOVE TECNOLOGIE
PER TRAMANDARE QUEST'ARTE
COL GIUSTO EQUILIBRIO
TRA TRADIZIONE E INNOVAZIONE.

F.lli Fogazza

LA STORIA THE HISTORY	2
LA PRODUZIONE THE PRODUCTION	4
CARATTERISTICHE TECNICHE T. SPECIFICATIONS.....	6
TINTA UNITA BASIC.....	9
MILLENNIUM CLASSICO-CLASSIC.....	25
FLEUR FLOREALI-FLOREAL	27
STUDIO GEOMETRICI-GEOMETRIC	73
ATLANTIS MODERNO-MODERN	119
PATCHWORK	120
PAVON	130
WAVE	131
SNAKE	132
MUSIVA	134
WOODSTONE	138
HAUTE COUTURE SU MISURA-TAYLOR MADE	147
ACCESSORI-ACCESSORIES.....	157
OLYMPIA	163
CUCINA KITCHEN	164
BAGNO BATHROOM	168

Palermo, città mitteleuropea



A partire dalla seconda metà dell'800, movimenti artistici desunti dalla cultura contemporanea mitteleuropea hanno trovato la massima espressione nel Liberty palermitano. Un periodo in cui la città vive un fermento di particolare vivacità sia economico che culturale, un'epoca d'oro nata grazie ad alcune importanti famiglie dotate di eccezionali capacità imprenditoriali: i Florio e i Whitaker.

Palermo diventa crogiuolo in cui prendono vita novità artistiche e culturali, polo d'attrazione per molti personaggi del mondo della scienza e della cultura, artisti e intellettuali che spingono verso una maggiore apertura in senso europeo.

Le aspirazioni della borghesia emergente si riverberano così sull'architettura: per avere una città che possa competere con le altre città Europee nascono edifici raffinati creati per lo spettacolo e il tempo libero, ville e giardini e residenze di prestigio.

Ne possiamo citare alcuni rari esempi - sopravvissuti all'incuria del tempo, delle guerre o dell'uomo - come il complesso "Florio" all'Olivuzza, il villino Favalaro-Di Stefano, il Grand Hotel "Villa Igia", la biblioteca di Palazzo Francavilla, il villino Basile, il teatro Biondo, Palazzo Agnello-Briuccia. Si sviluppa così un concetto d'architettura intesa come "opera d'arte in tutto" che si

concretizza in oggetti d'arredo, affreschi e maioliche, in particolare il vetro e il ferro battuto costituiscono una vera e propria innovazione che consente lo sviluppo di una sorta di "scultura-architettura".

Artigiani, decoratori, mosaicisti, fabbri e vetrai sono chiamati quindi ad inserire negli edifici le proprie produzioni, dettagli di eccezionale fattura che impreziosiscono e rendono unico il Liberty palermitano.

In sintonia con tale tendenza, nella realizzazione di rivestimenti, si diffonde il ricorso alla "cementina" in sostituzione alle maioliche "Riggiole", così da creare pavimenti più resistenti e duraturi nel tempo.

È proprio in questo fervore culturale e artistico che nasce una solida realtà aziendale che opera da oltre un secolo nel settore dei pavimenti in graniglia. Dal 1905 ad oggi l'azienda Fogazza ha saputo mantenere quella tradizione ispirata al ricco e variegato universo del Liberty cercando sempre nuove ispirazioni e nuovi spunti inventivi per creare un prodotto perfetto anche per gli ambienti moderni.

Il processo di creazione artigianale si ripete nella gestualità oggi come allora, le marmette nascono una per volta mescolando i colori e versando a mano il composto negli stampi.

Ricercatezza e particolarità, autenticità e unicità rendono le marmette Fogazza il dettaglio che fa la differenza sia in un ambiente classico che moderno.



Palermo, mitteleuropean city



Starting from the second half of the 1800s, artistic movements inspired by contemporary culture in Central Europe found their ultimate expression in the Liberty of Palermo. A time when the city is experiencing heightened economic and cultural vibrance, a golden age sparked by some notable families with exceptional entrepreneurial skills: the Florio and Whitaker. Palermo becomes the crucible where artistic and cultural creativity come to life, a magnet for many personalities from the world of science and culture, artists and intellectuals who are pushing for greater openness on a European level. The aspirations of the emerging middle class thus reverberate on architecture: to have a city that can

compete with the other capitals of Europe, refined buildings are built for entertainment and leisure, villas, gardens and residences of high prestige. We can mention some rare examples that have survived the ravages of time, wars or human negligence - like the "Florio" complex all'Olivuzza, villa Favalaro-Di Stefano, the

Grand Hotel "Villa Igea", the library of Palazzo Francavilla, villa Basile, the Biondo theatre, Palazzo Agnello-Briuccia.

A concept of architecture originates understood as "artwork everywhere" that takes the form of ornaments, frescos and pottery. Glass and wrought iron in particular represent a genuine innovation that enables the development of a kind of "sculpture-architecture". Craftsmen, decorators, mosaicists, locksmiths and glaziers are called then to add their artifacts to buildings, ornamental items of extraordinary workmanship that enrich the Liberty of Palermo and make it unlike any other. In keeping with this trend, builders begin to use "cementina" in foundational works to replace the "Riggiole" majolica, with the aim of creating more durable and long-lasting floors. It is precisely in the midst of this cultural and artistic fervour that a solid business develops, which for over a century has manufactured floors in graniglia. From 1905 to our present day, Fogazza has known how to keep that tradition inspired by the rich and diverse world of Liberty well alive, always looking for new inspiration and new ideas, to create a product that perfectly suits also the modern living space.

The handcrafted creative process is the repetition of an intricate series of gestures. Now as back then, the tiles are manufactured one at a time, by mixing colours and pouring the mixture into the moulds. Refinement and detail, authenticity and uniqueness make Fogazza tiles the detail that makes the difference in both a classical and modern environment.

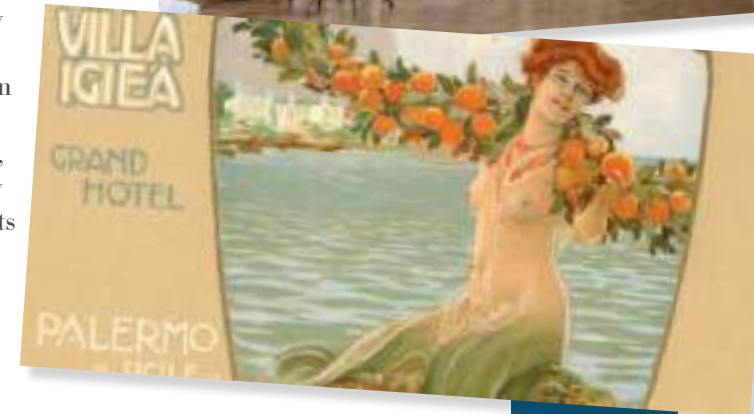



Guarda video
Watch video

LA PRODUZIONE TRADIZIONALE TRADITIONAL PRODUCTION



1. Divisionale nello stampo/Slide divider into mould

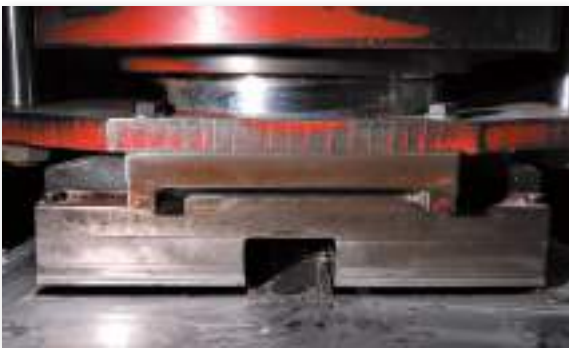

4. Pressatura/Press



2. Colatura impasto/Pour mixture



5. Sformatura/Remove from mould



3. Spolvero
Create base



6. Prodotti grezzo
Unprocessed product



7. Prodotti finito
Finished product



LA PRODUZIONE INDUSTRIALE INDUSTRIAL PRODUCTION

Guarda video
Watch video



1. Versamento dell'impasto/Batch out mixture



4. Levigatura/Polishing



2. Pressatura/Press tile



5. Bisellatura/Chamfering



3. Sformatura/Remove tile from mould

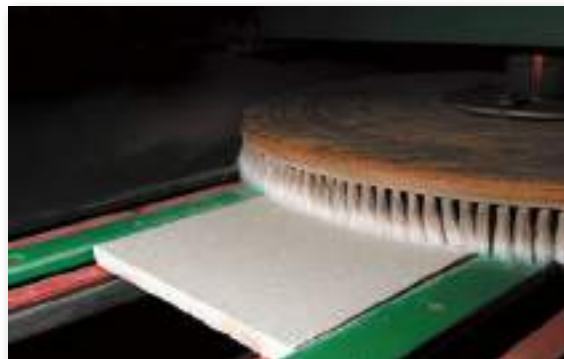

6. Trattamento/Treatment



7. Scatolatura/Boxing

CARATTERISTICHE TECNICHE/TECHNICAL SPECIFICATIONS

FORMATO/FORMAT

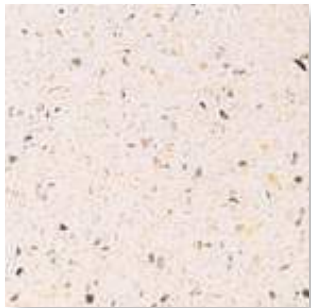

- 10x10x1,3 cm
- 10x20x1,3 cm
- 20x20x1,3 cm
- 25x25x1,4 cm
- 40x40x1,8 cm
- ESAGONO 11,6x11,6x1,6 cm
- ESAGONO 20x20x1,8 cm

MARMETTA
MONOSTRATO
FOGAZZA

FOGAZZA
SINGLE
LAYER TILE

MARMETTA
BISTRATO

DOUBLE
LAYER TILE



13 mm



5 mm | 10 mm

I VANTAGGI DELLA GRANIGLIA

- Versatilità decorativa
- Alta resistenza nel tempo
- Basso assorbimento
- Sempre di tendenza
- Semplicità d posa
- Rilevigabile nel tempo
- Componenti naturali

THE ADVANTAGES OF GRANIGLIA

- Decorative versatility
- High durability
- Low absorption
- Always trendy
- Easy installation
- Multiple repolishing over time
- Natural components

CARATTERISTICHE TECNICHE/TECHNICAL SPECIFICATIONS

FINITURE/FINISH

LEVIGATA (LV)

Superficie levigata. Dopo la posa in opera è consigliabile la lucidatura tradizionale e trattamento antimacchia.



HONED (LV)

An anti-skid, honed surface. After assembly, traditional polishing and stain-proof treatments are advised.

ANTICATA (AK)

Superficie con effetto buccia d'arancia e antiscivolo e bisellata. Dopo la posa in opera si consiglia un trattamento antimacchia superficiale.



ANTIQUÉ (AK)

An anti-skid, slightly rough surface in which marble aggregates are exalted. A stain-proof treatment, however, is advised.

LUCIDA (LCD)

Superficie lucida e bisellata. Dopo la posa in opera si consiglia un trattamento antimacchia superficiale.



POLISHED (LCD)

Polished and chamfered surface. A stain-proof treatment, however, is advised.

OPACA (PO)

Superficie semi lucida e bisellata. Dopo la posa in opera si consiglia un trattamento antimacchia superficiale.



MATT (OP)

A slightly semi-polished surface, does not require any post-installation intervention. A stain-proof treatment, however, is advised.

IMPORTANTE

I colori riprodotti in questo catalogo sono indicativi.
Le miscele e gli impasti sono costituiti da prodotti naturali e quindi dalle cromie variabili.

WARNING

The colours shown in this catalogue are indicative.
The mixes and blends are made up of natural products and colours will therefore vary.



TINTA UNITA

>>> BASIC

Il piacere della classica semplicità, il gusto di arredare la casa utilizzando solo la forza del colore. Un materiale caldo e vissuto come la graniglia o la pura compattezza della pasta per riscaldare gli ambienti della casa. La collezione Tinta Unita è puro colore, come scenografia monocroma di un palcoscenico dove gli unici protagonisti sono gli arredi della casa.

The pleasure of classic simplicity, the taste of decorating the home, using only the power of colour. A warm, vintage material like graniglia, or the pure compactness of pasta to warm up the living space. The Tinta Unita collection is pure colour, like the monochrome design of a stage where the only protagonists are the furnishings of the home.

FOGAZZA

TINTA UNITA

GRANIGLIA



AVORIO



BIANCO



GIALLO



SALMONE



ROSSO



ROSA



VERDINO



MARRONE



GRIGIO



VERDE



AZZURRO



NERO

TINTA UNITA

PASTINA



AVORIO



GIALLO



SALMONE



ROSSO



VERDE



GRIGIO



MARRONE



SABBIA



AZZURRO



NERO













ESAGONO

GRANIGLIA



AVORIO

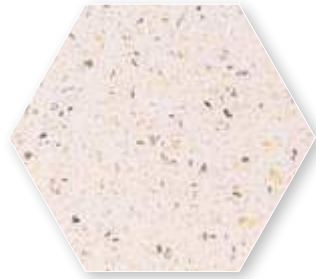

BIANCO



GIALLO

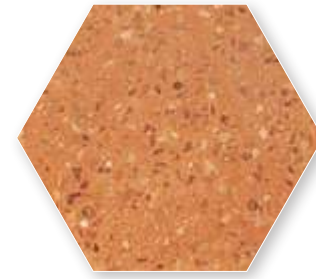

SALMONE

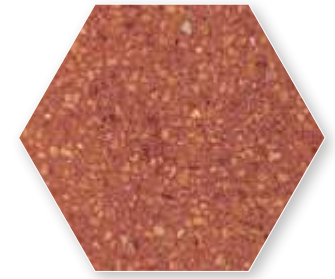

ROSSO

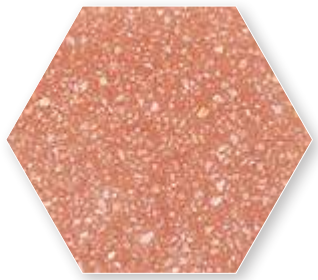

ROSA

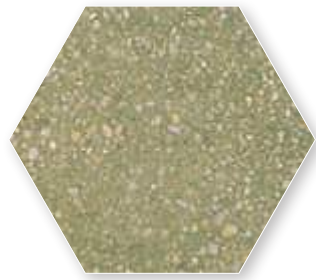

VERDINO



MARRONE

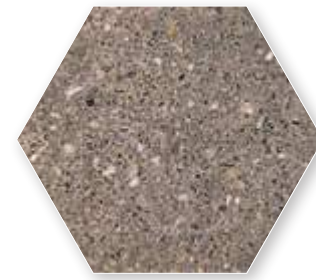

GRIGIO

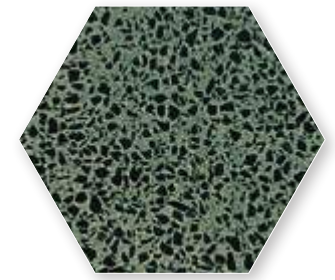

VERDE

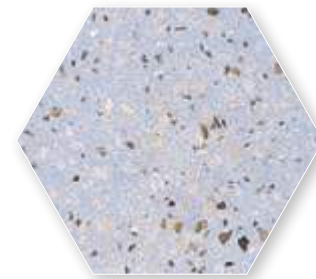

AZZURRO

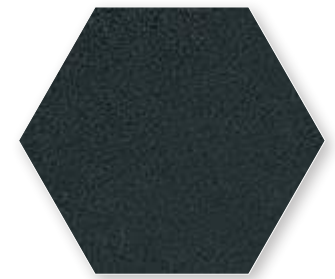

NERO

ESAGONO

PASTINA

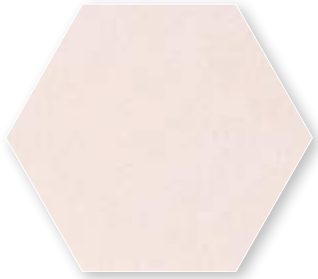

AVORIO

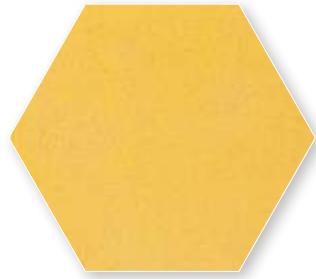

GIALLO



SALMONE

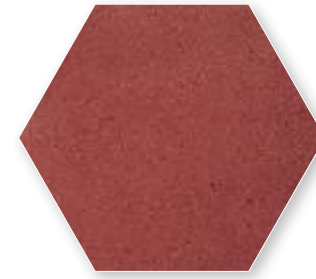

ROSSO



VERDE



GRIGIO



MARRONE



SABBIA

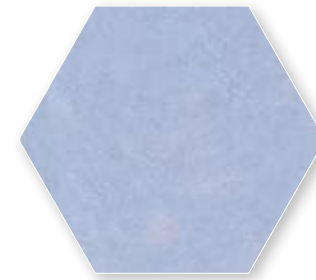

AZZURRO



NERO









Believe
in your
dreams





MILLENNIUM

>>> CLASSICO

Vivere il presente con la volontà di fermare il tempo, impegnarsi nella ricerca di un nostalgico stile retrò da reinventare ed attualizzare. La linea Millennium è dedicata a chi vuol fare della propria casa un oggetto d'arte da vivere, per chi cerca la cura del dettaglio anche nel più piccolo particolare. Marmette uniche, prodotti artigianali dai decori liberty, nate dalle sapienti mani di maestri d'arte che lavorano ancora seguendo le tecniche d'inizio secolo.

To experience the present with the desire to stop time, seeking a nostalgic, retro style to be reinvented and updated every time.

The Millennium line is dedicated to those who want to make their home a work of art to enjoy, for those seeking the minutest care for detail. Unique tiles, handcrafted products in Liberty style, the work of skilled hands of master artists who still craft their works following the techniques in vogue at the beginning of the century.

FOGAZZA





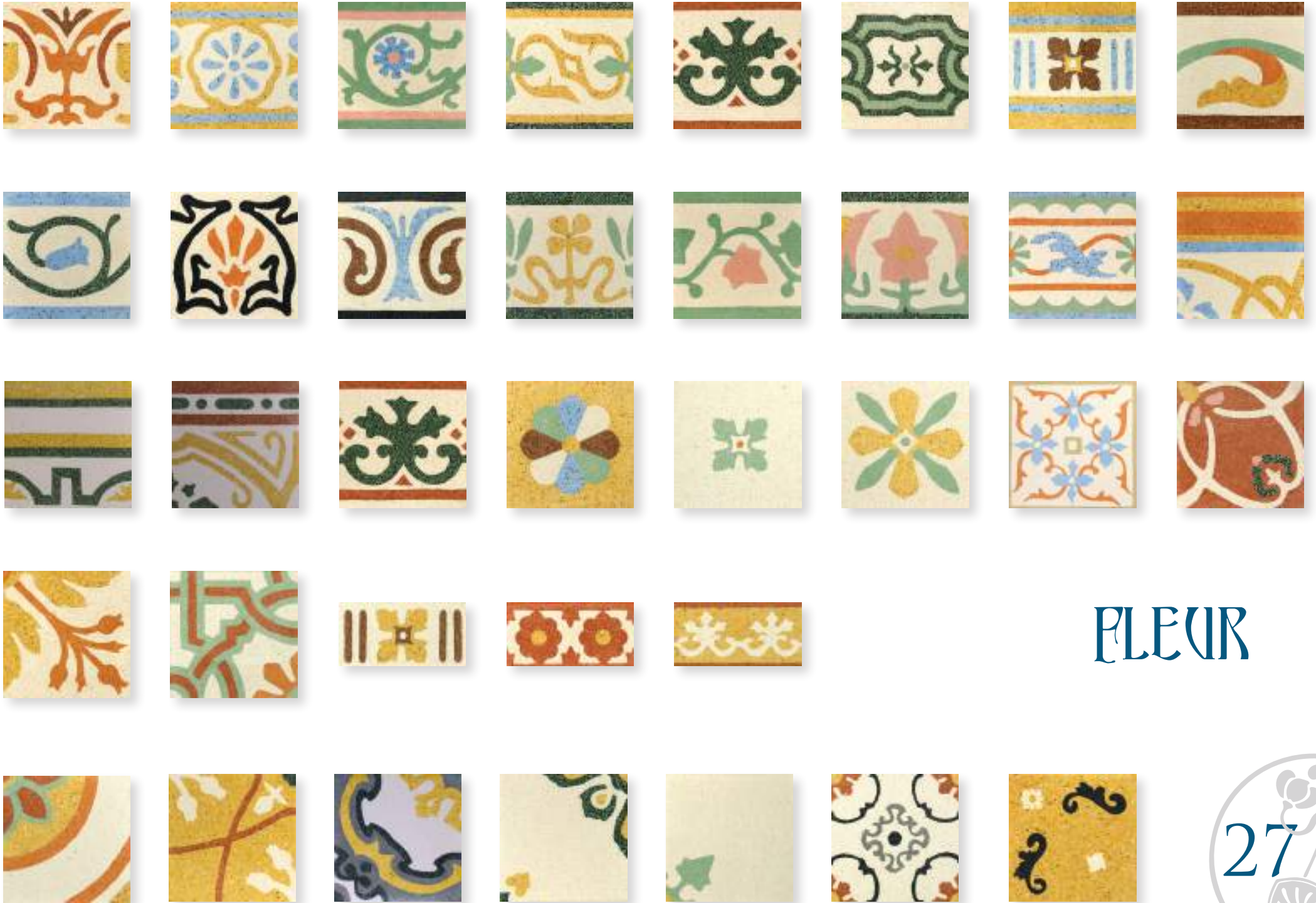

PLEUR

FLEUR Bordure Semplici

formato/format 20x20x1,3 cm

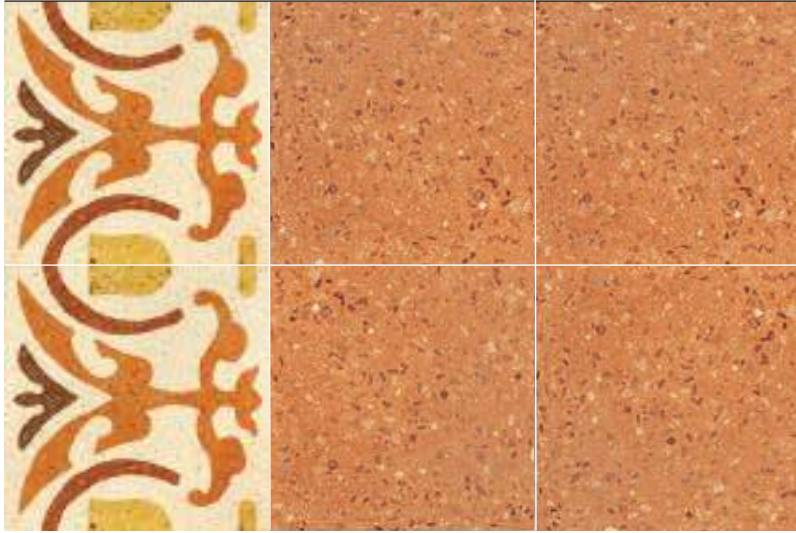
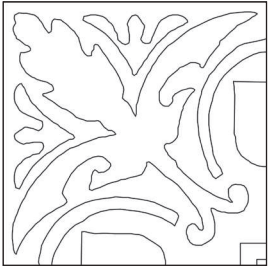

BDS 102

Florio



MILLENNIUM



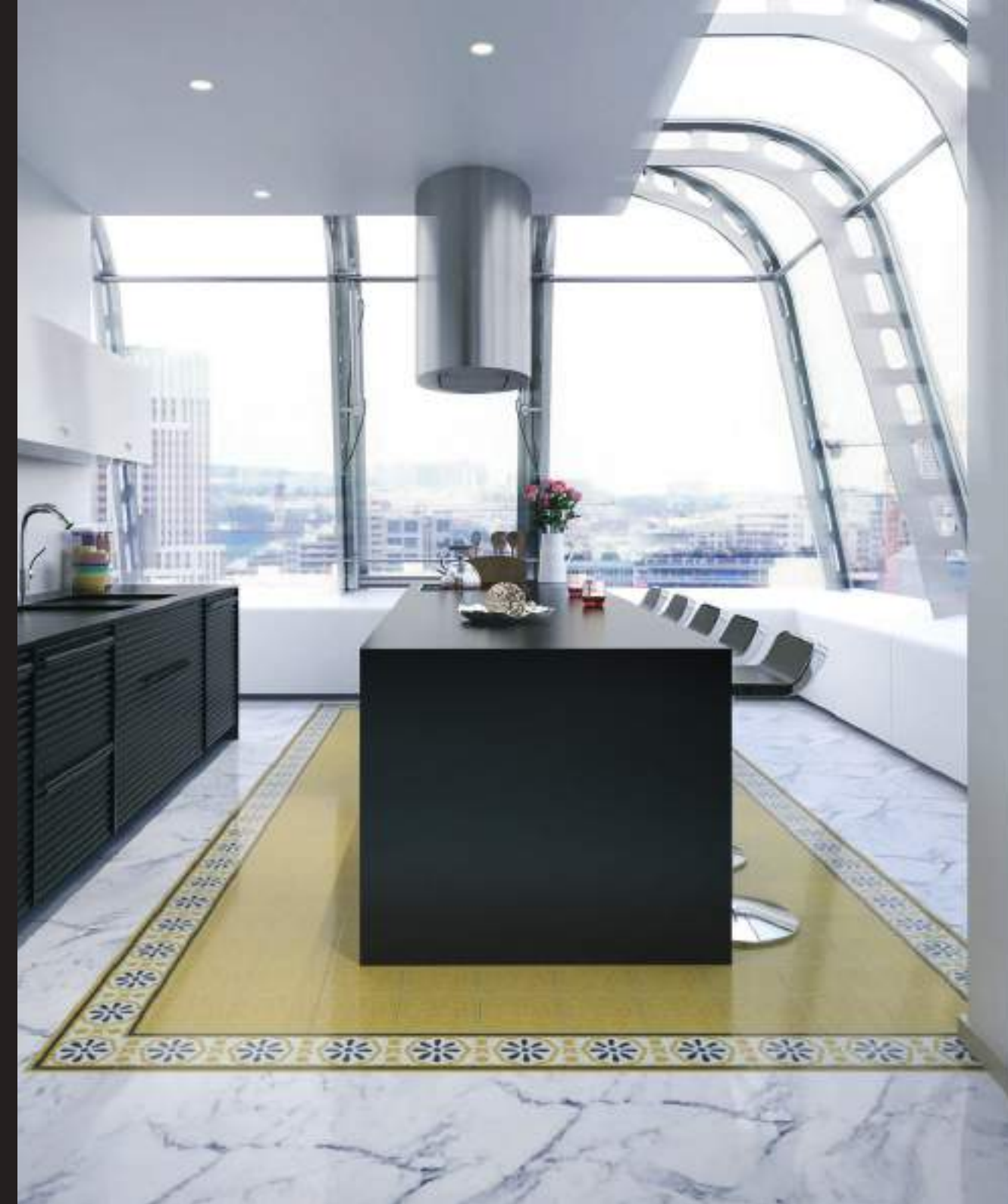

formato/format 20x20x1,3 cm

FLEUR Bordure Semplici

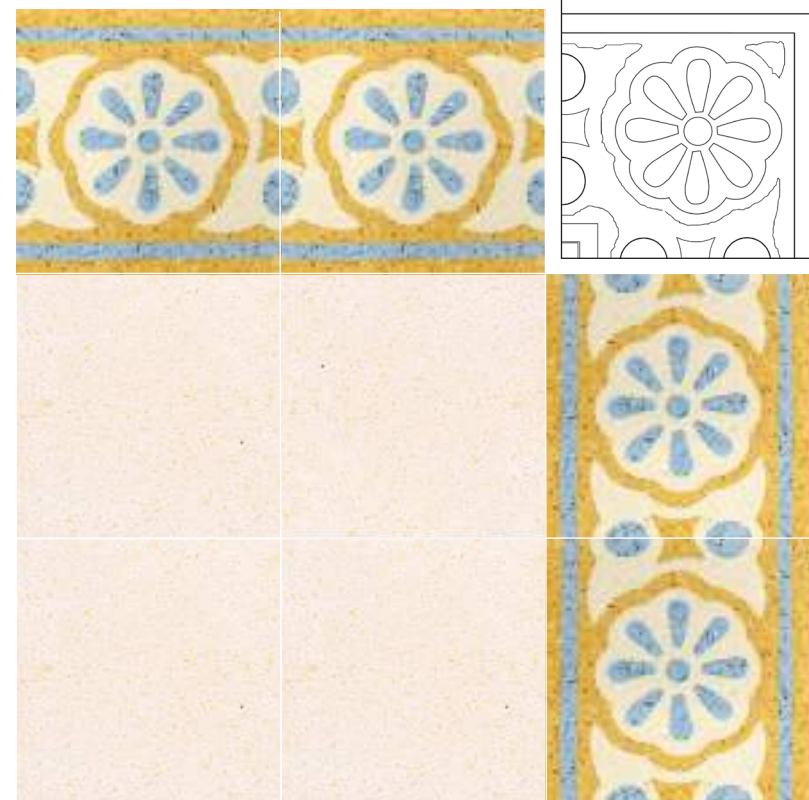

BDS 106

Kalsa

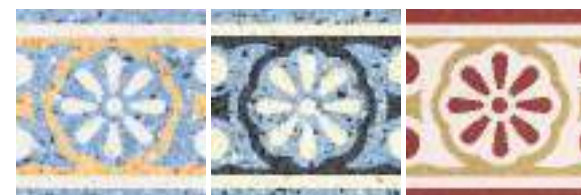

MILLENNIUM



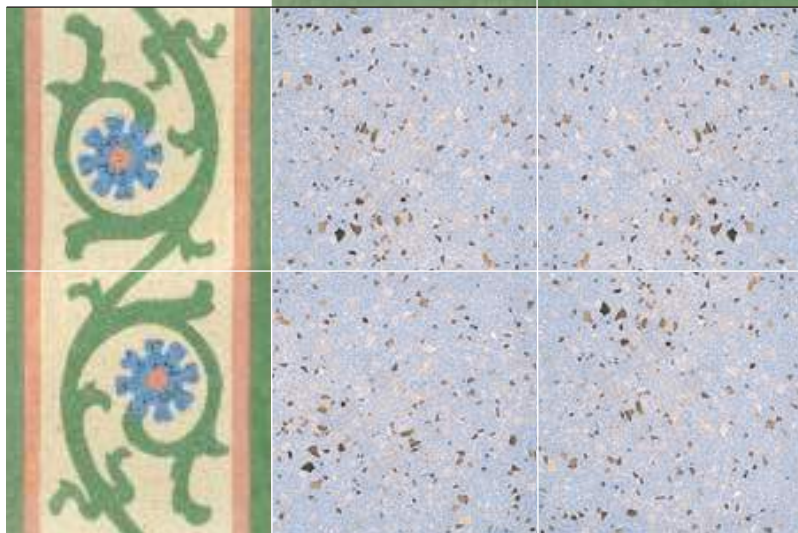
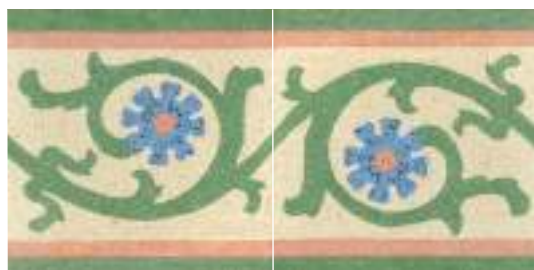
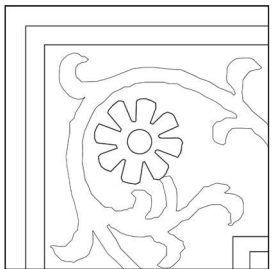

BDS 107

*Nella progettazione delle bordure si consiglia di utilizzare un numero dispari di decori per lato, in modo da non interrompere la continuità del disegno.

* When preparing borders, it is recommended to make use of an odd number of decoration elements on each side so as not to disrupt the continuity of the design

Ignea*



MILLENNIUM





formato/format 20x20x1,3 cm

FLEUR Bordure Semplici

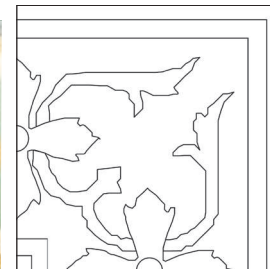

BDS 108

Deco



MILLENNIUM



FLEUR Bordure Semplici

formato/format 20x20x1,3 cm

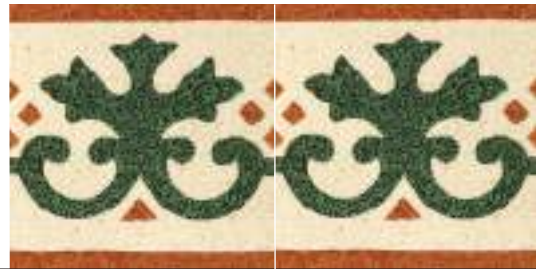
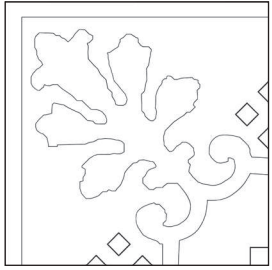

BDS 111

Dacrot



MILLENNIUM



formato/format 20x20x1,3 cm

FLEUR Bordure Semplici

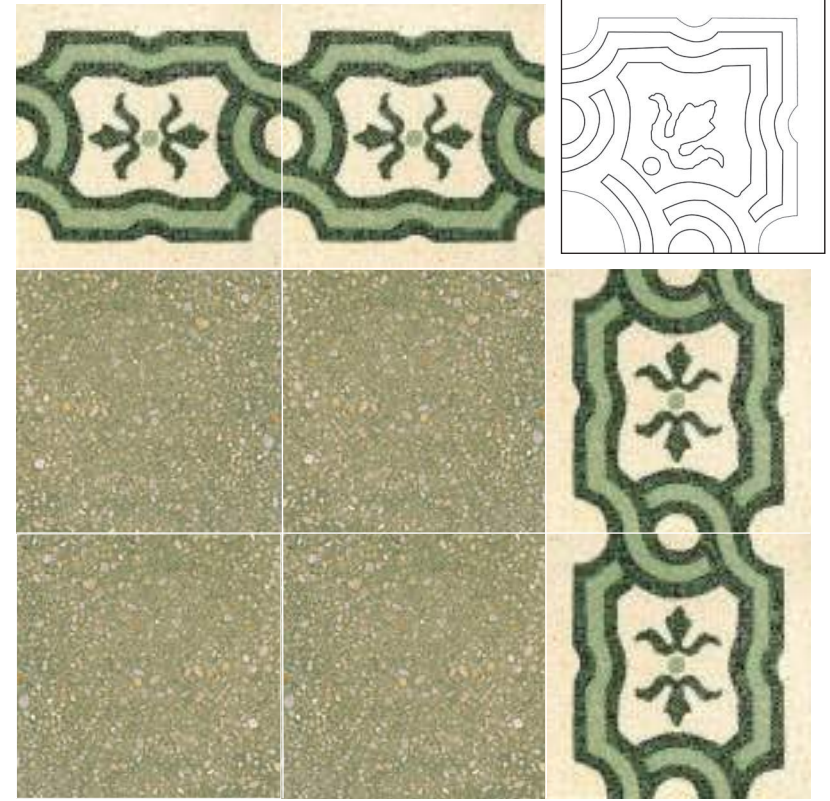

BDS 113

Remonia



MILLENNIUM

33



FLEUR Bordure Semplici

formato/format 20x20x1,3 cm

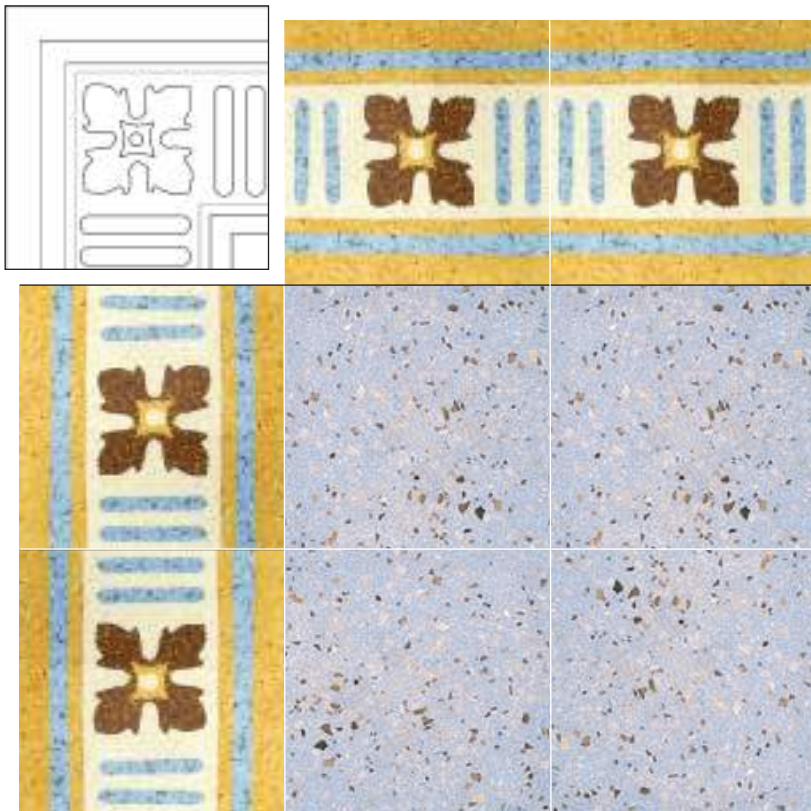

BDS 114

Quattro Canti



MILLENNIUM





formato/format 20x20x1,3 cm

FLEUR Bordure Semplici



*Nella progettazione delle bordure si consiglia di utilizzare un numero dispari di decori per lato, in modo da non interrompere la continuità del disegno.

BDS 115

* When preparing borders, it is recommended to make use of an odd number of decoration elements on each side so as not to disrupt the continuity of the design

Corinto*



MILLENNIUM



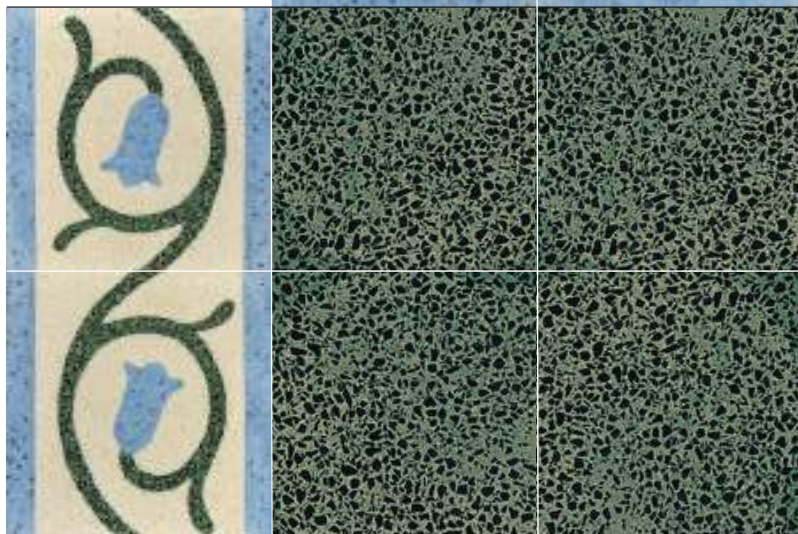
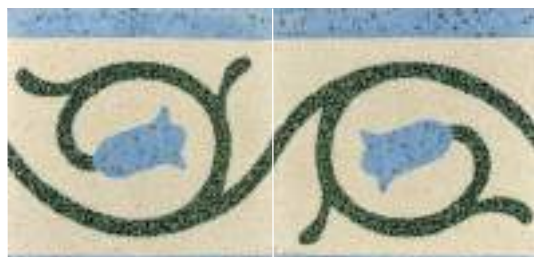
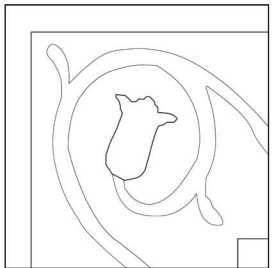

BDS 117

* Nella progettazione delle bordure si consiglia di utilizzare un numero dispari di decori per lato, in modo da non interrompere la continuità del disegno.

* When preparing borders, it is recommended to make use of an odd number of decoration elements on each side so as not to disrupt the continuity of the design

Bouquet



MILLENNIUM





formato/format 20x20x1,3 cm

FLEUR Bordure Semplici



BDS 118

Flamboiant



MILLENNIUM

37





BDS 121

Rami di corallo



MILLENNIUM





FLEUR Bordure Semplici

formato/format 20x20x1,3 cm



BDS 122

Zisa



MILLENNIUM





formato/format 20x20x1,3 cm

FLEUR Bordure Semplici

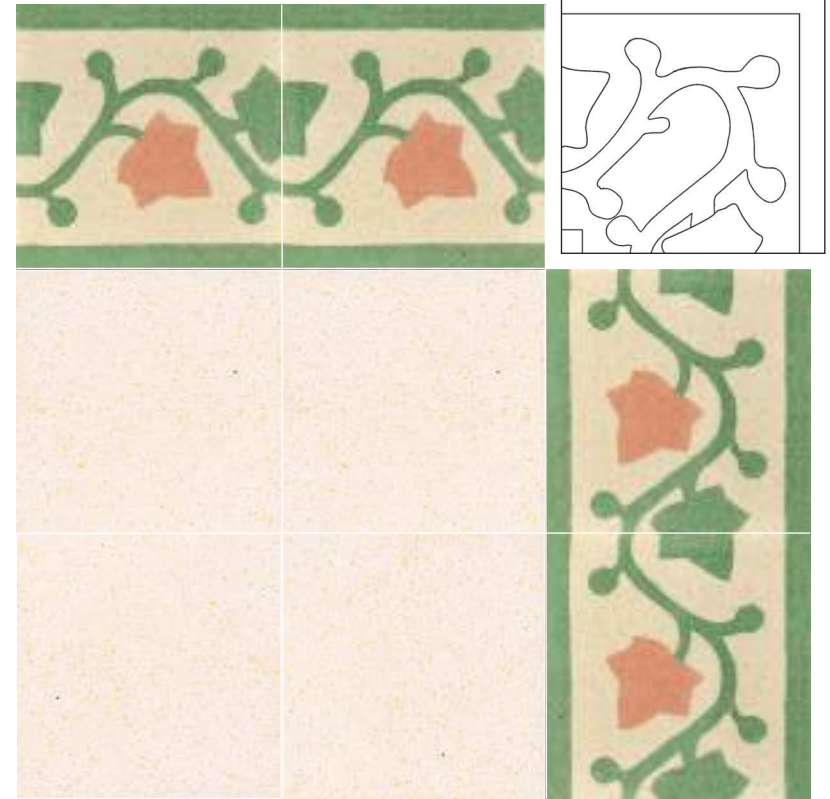

BDS 126

Floralia

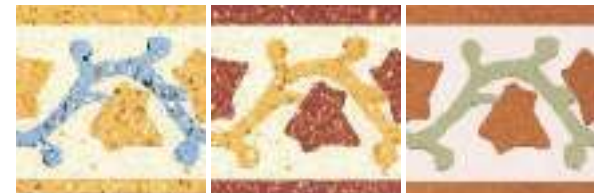

MILLENNIUM



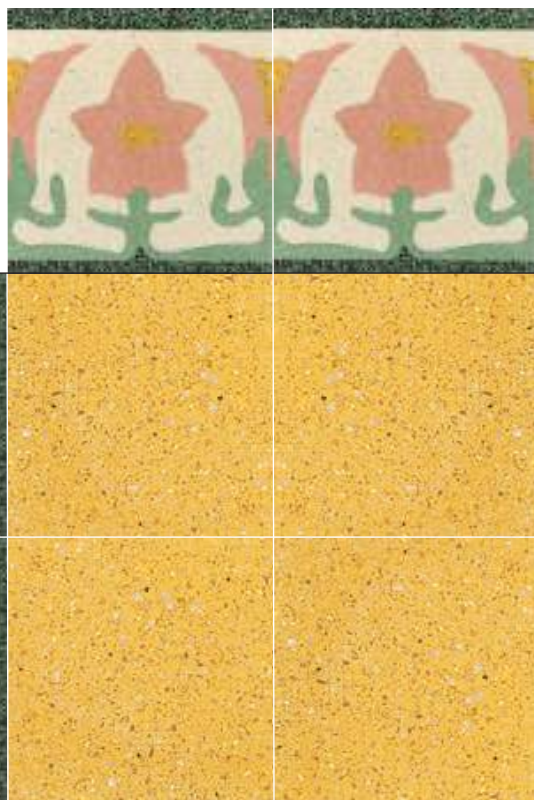

BDS 129

Basile



MILLENNIUM





formato/format 20x20x1,3 cm

FLEUR Bordure Semplici



BDS 131

Dolcemare



MILLENNIUM

43





BDD 201

Ballarò



MILLENNIUM





formato/format 20x20x1,3 cm

FLEUR Bordure Doppie

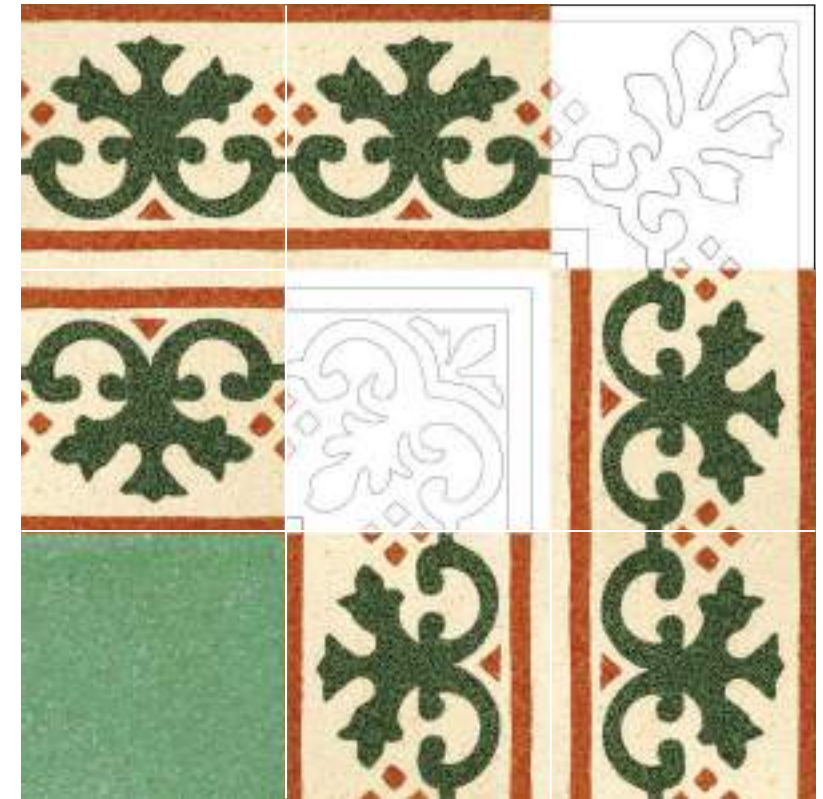

Acquasanta

BDD 204



MILLENNIUM





formato/format 20x20x1,3 cm

FLEUR Bordure Doppie



Vacciria

BDD 202



MILLENNIUM



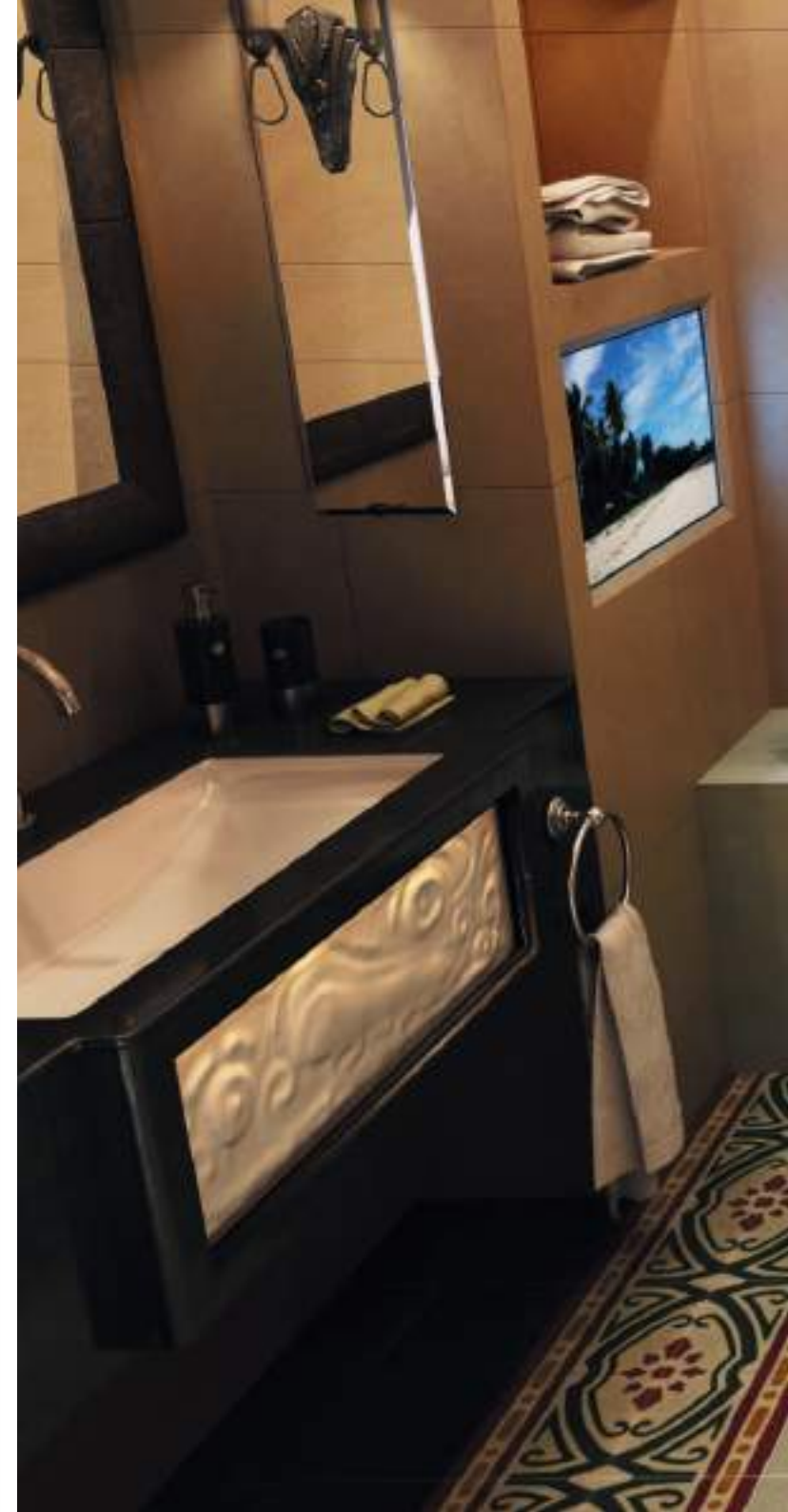

BDD 203

Mondello

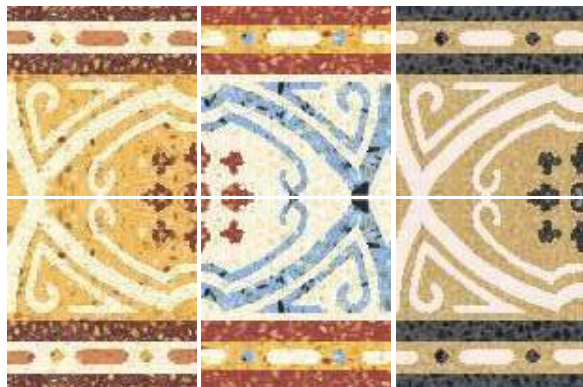

MILLENNIUM



FLEUR Fasce

formato/format 20x10x1,3 cm

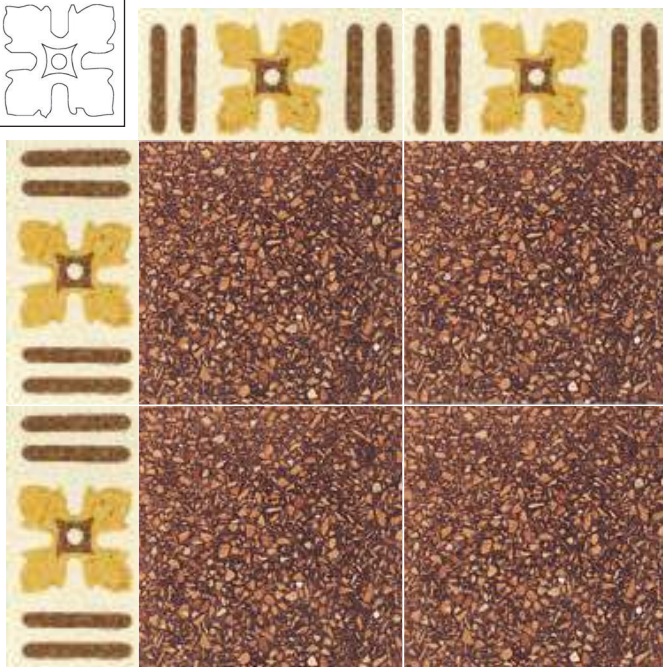
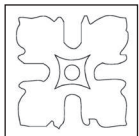

FSC 300

Quadrifoglio



MILLENNIUM





formato/format 20x10x1,3 cm

FLEUR Fasce

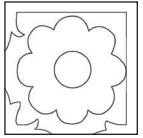

FSC 301

Giardino d'inverno



MILLENNIUM

51



FLEUR Fasce

formato/format 20x10x1,3 cm

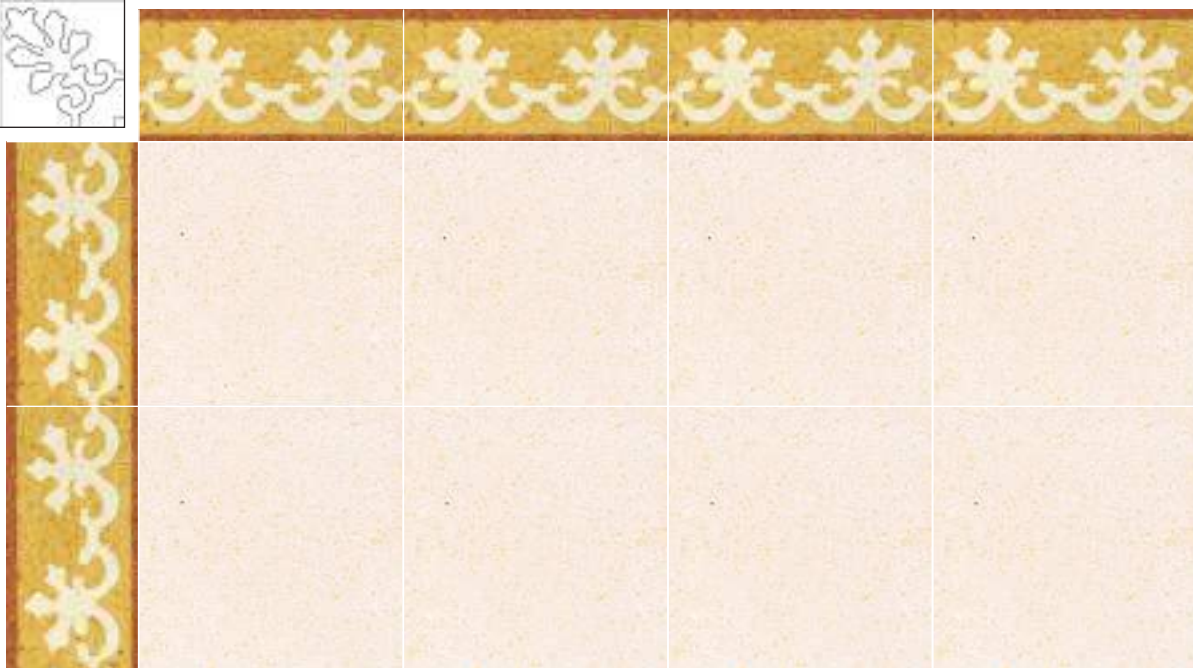

FSC 307

Poglie gotiche



52

MILLENNIUM



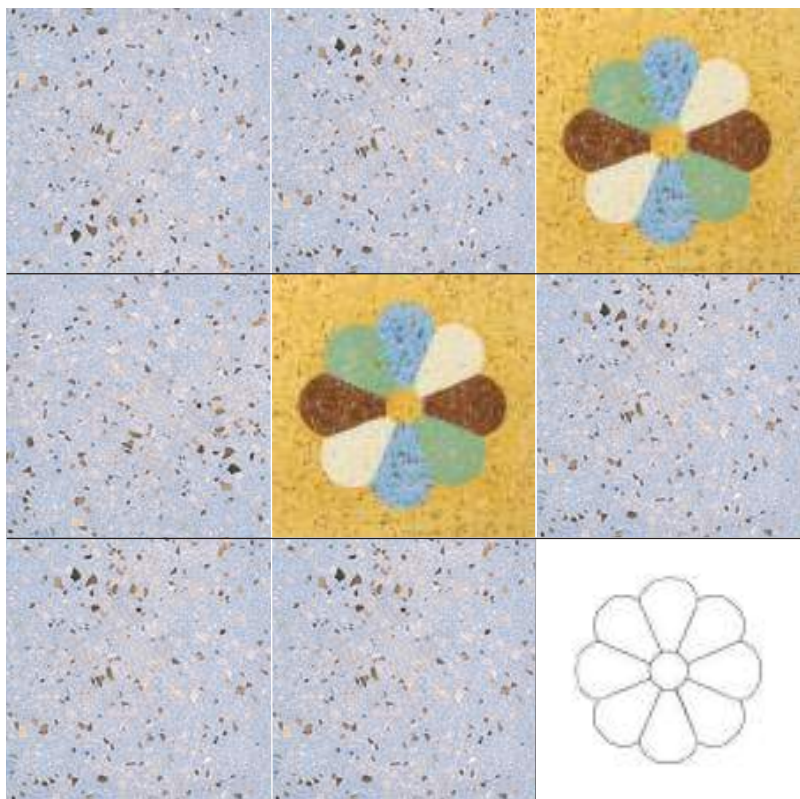

DEC 401

Peonie



MILLENNIUM





formato/format 20x20x1,3 cm

FLEUR Decori

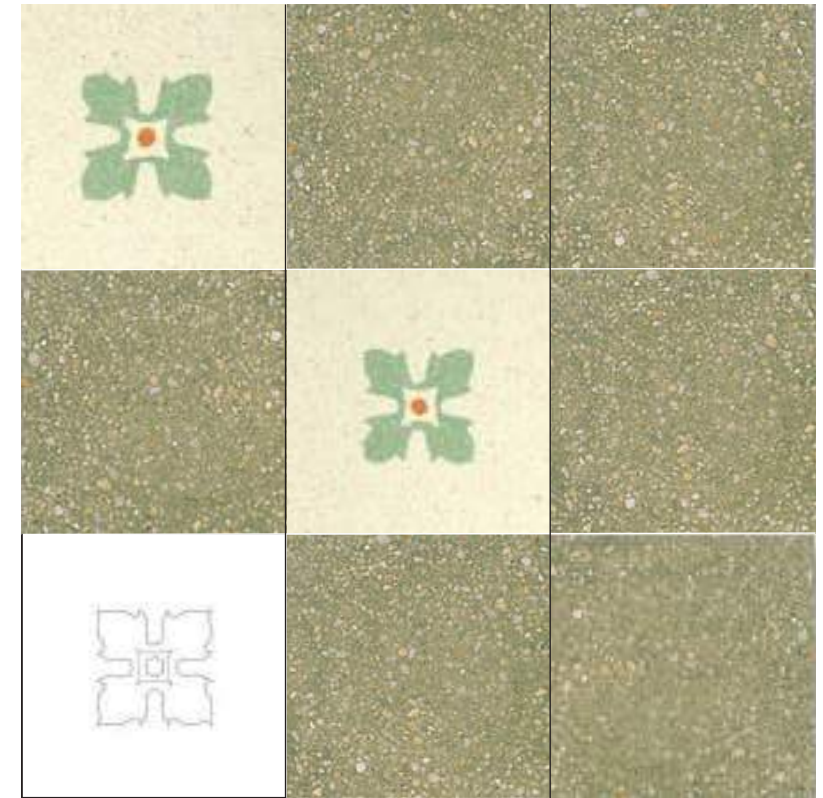

DEC 402

Iris



MILLENNIUM



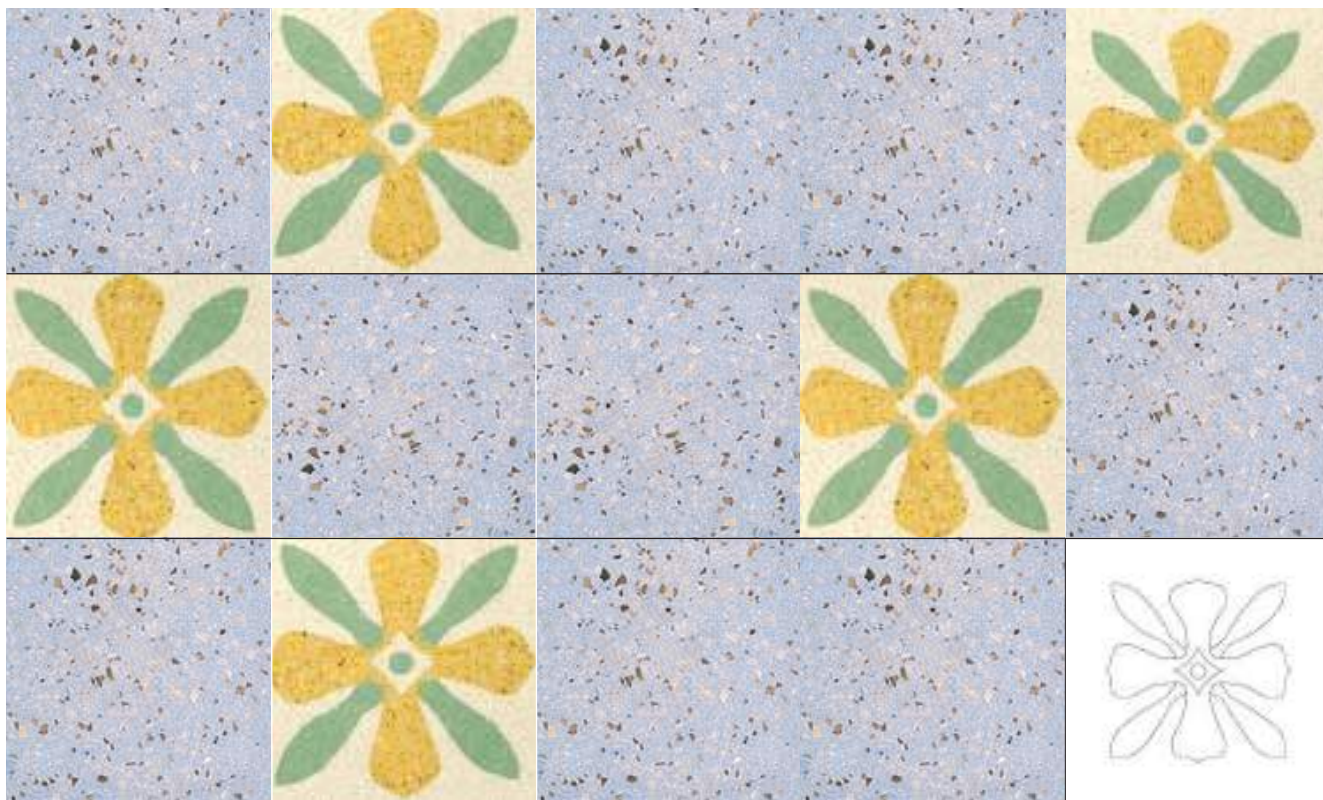

DEC 404

Fiore di melograno



MILLENNIUM









formato/format 20x20x1,3 cm

FLEUR Decori



DEC 405



Quattro fiori



MILLENNIUM



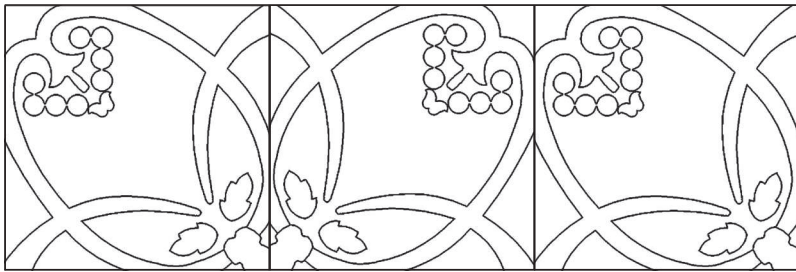
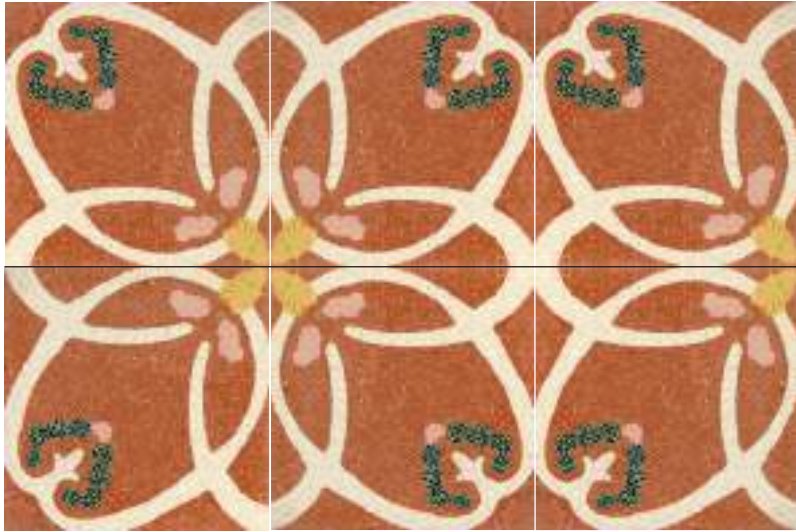

TPT 500

Anni Venti



MILLENNIUM





formato/format 20x20x1,3 cm

FLEUR Tappeti

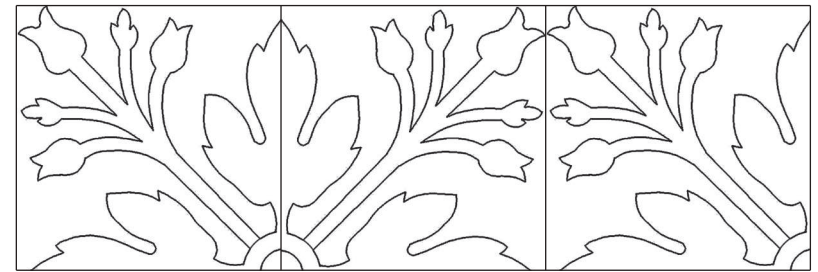
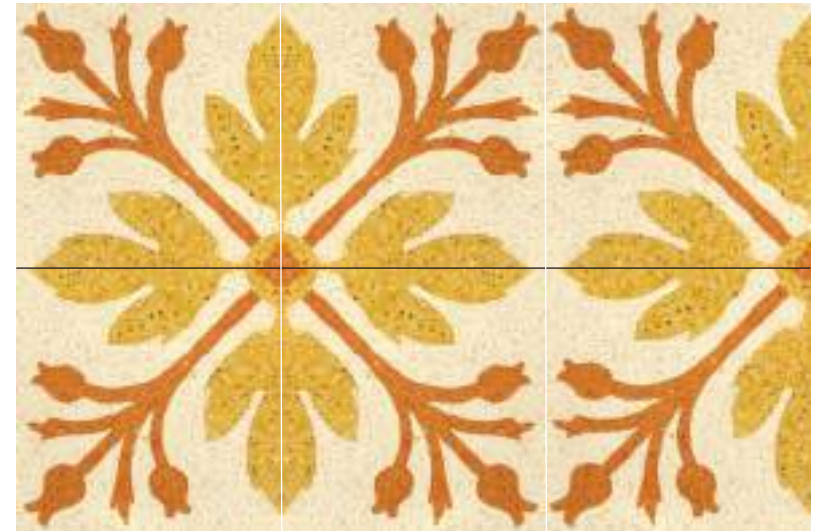

TPT 501

Papireto



MILLENNIUM



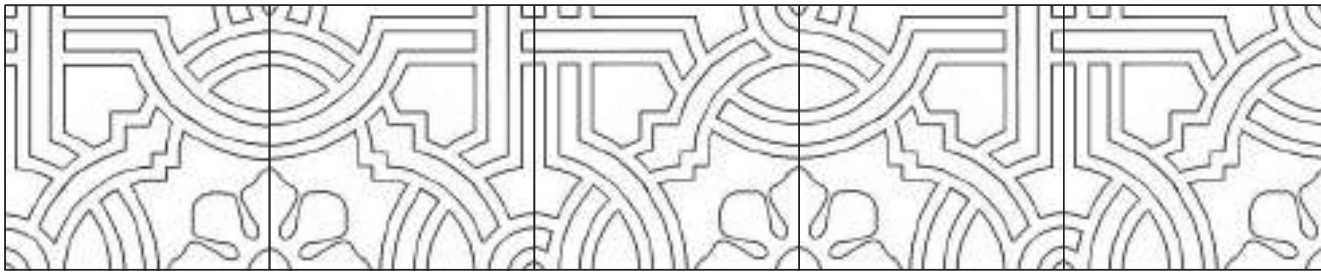
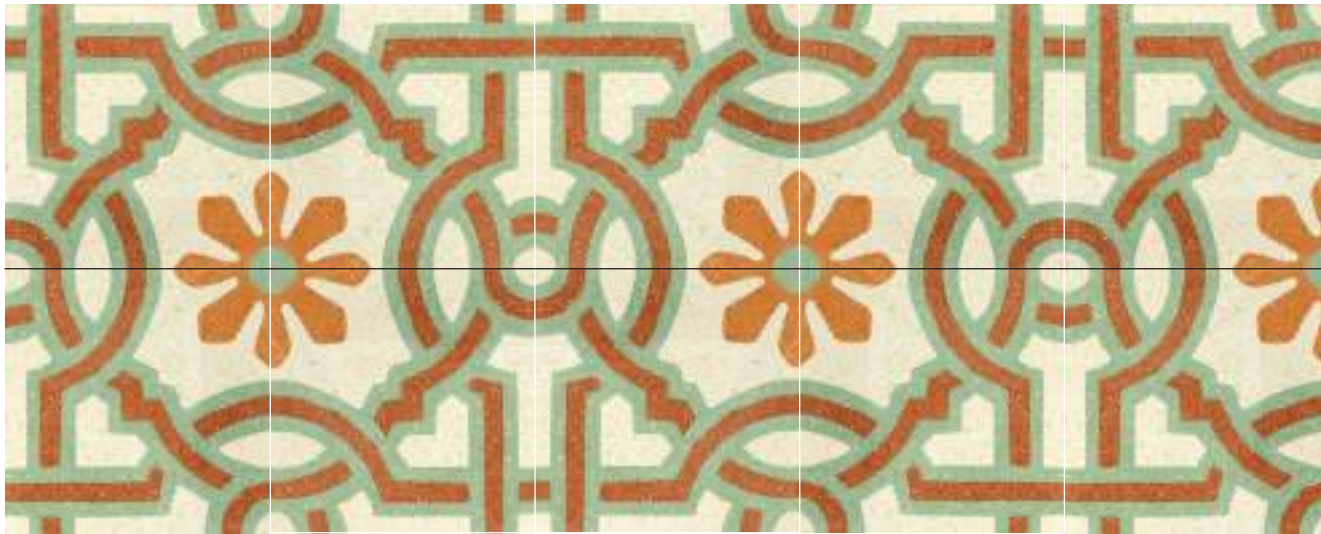

TPT 503

Moresco



MILLENNIUM







formato/format 20x20x1,3 cm

FLEUR Tappeti

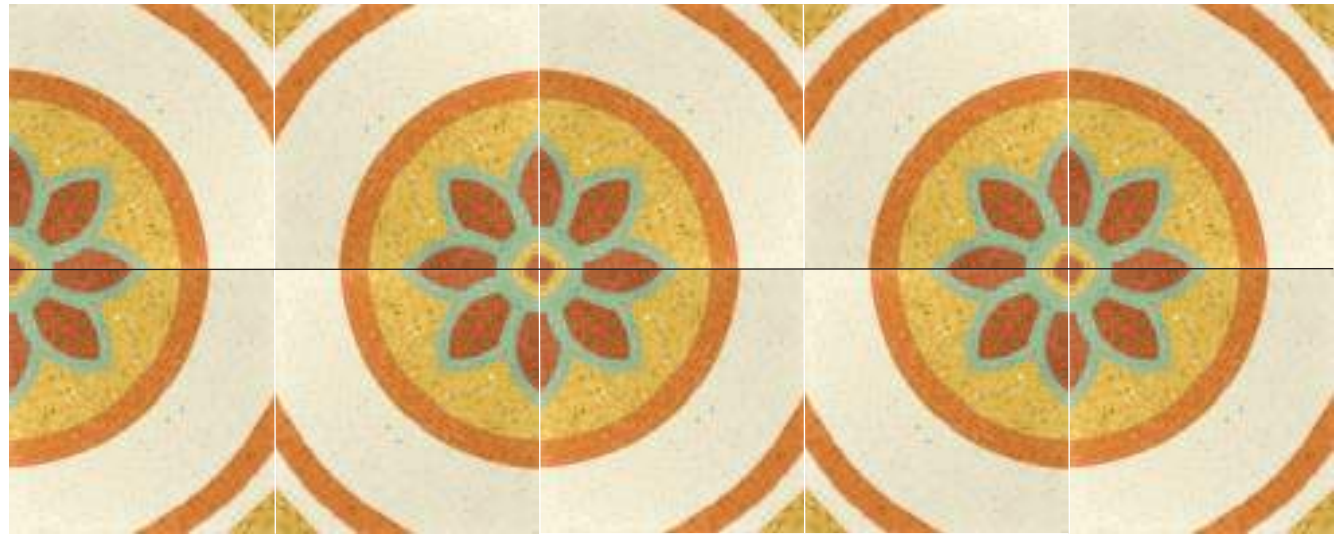

TPT 504

Rosone



MILLENNIUM



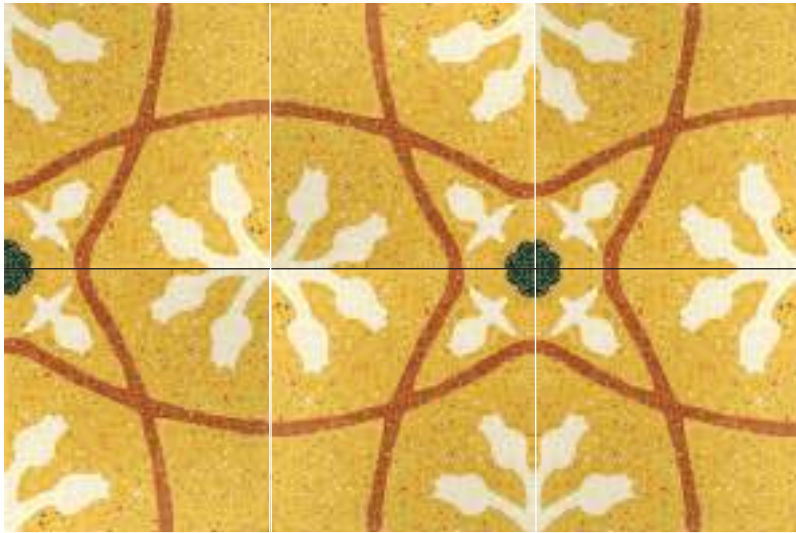

TPT 505

Piligrana

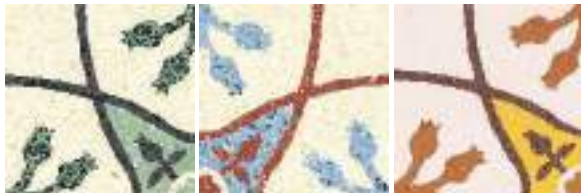

MILLENNIUM





formato/format 20x20x1,3 cm

FLEUR Tappeti

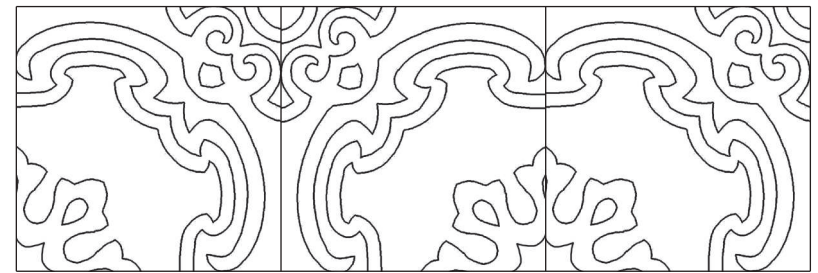

TPT 506

Barocco



MILLENNIUM



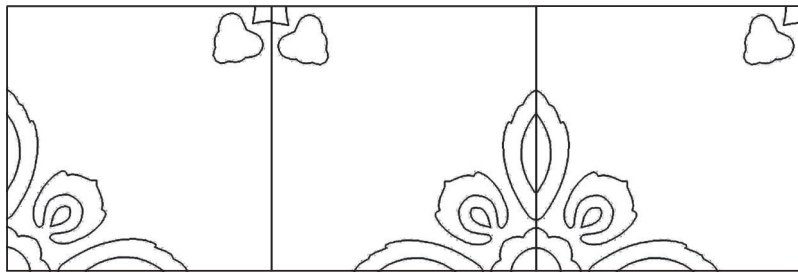
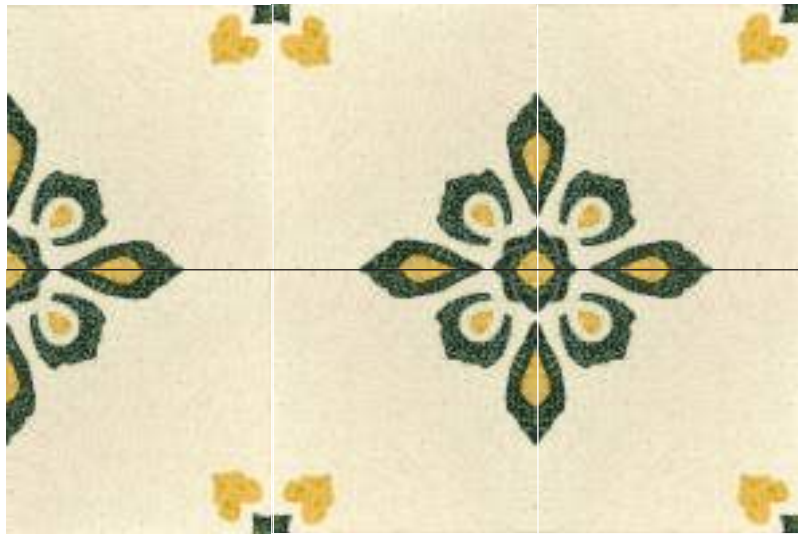

TPT 510

Miniature

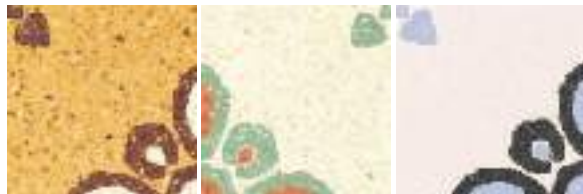

MILLENNIUM





formato/format 20x20x1,3 cm

FLEUR Tappeti

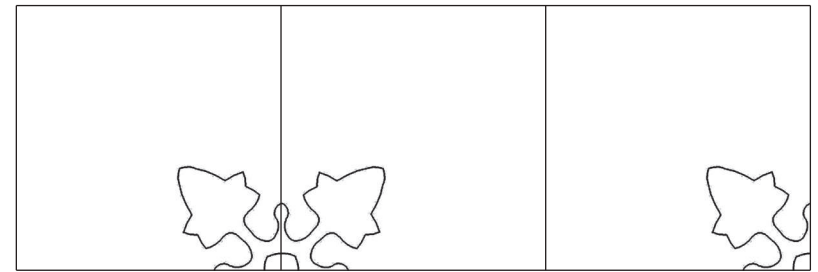
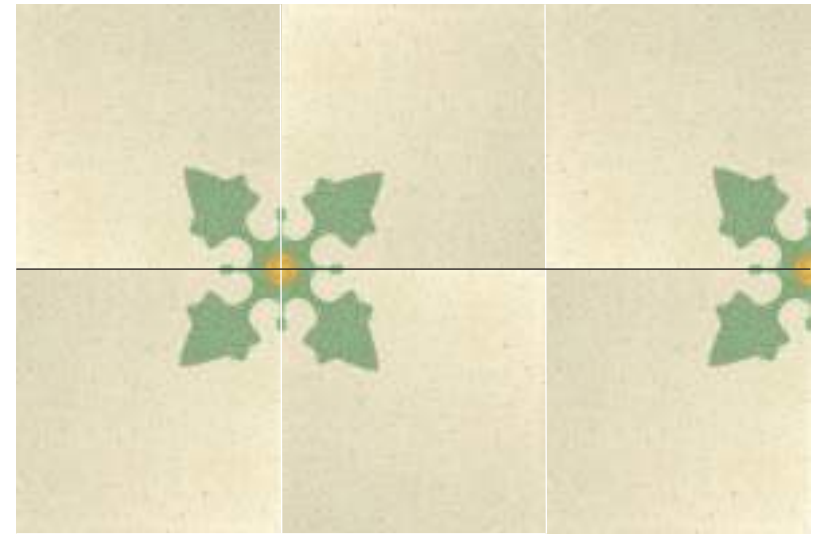

TPT 513

Quattro pizzi



MILLENNIUM



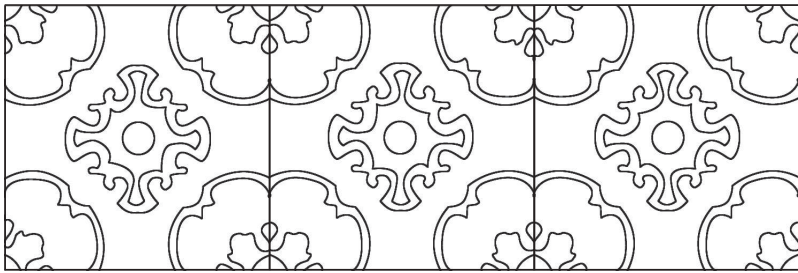

TPT 514

La Magione



MILLENNIUM





formato/format 20x20x1,3 cm

FLEUR Tappeti

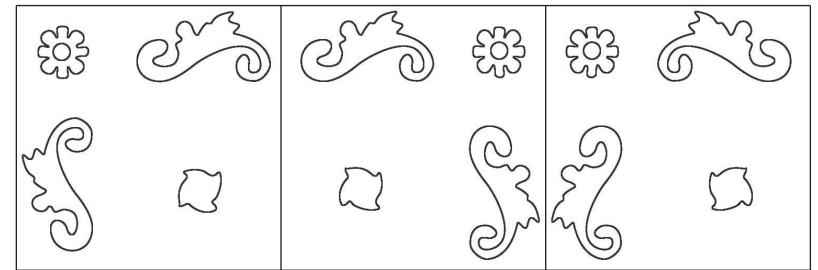
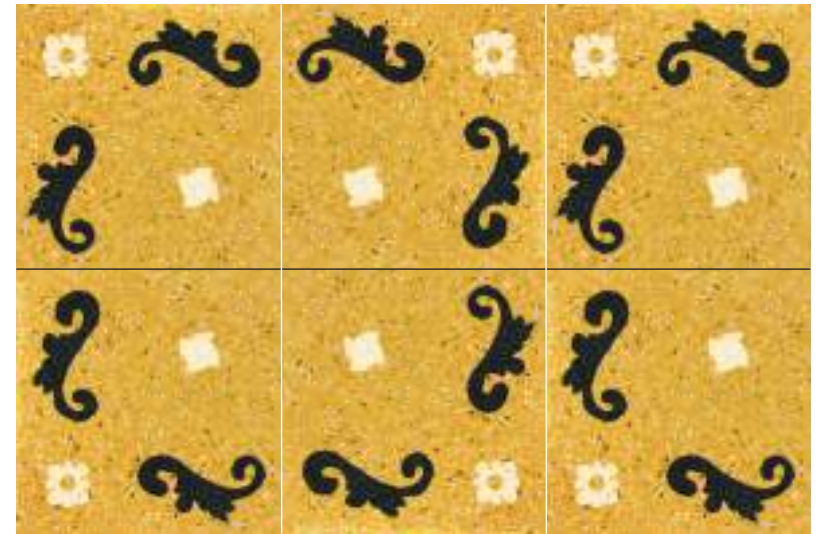

TPT 516

Petalo di rose



MILLENNIUM





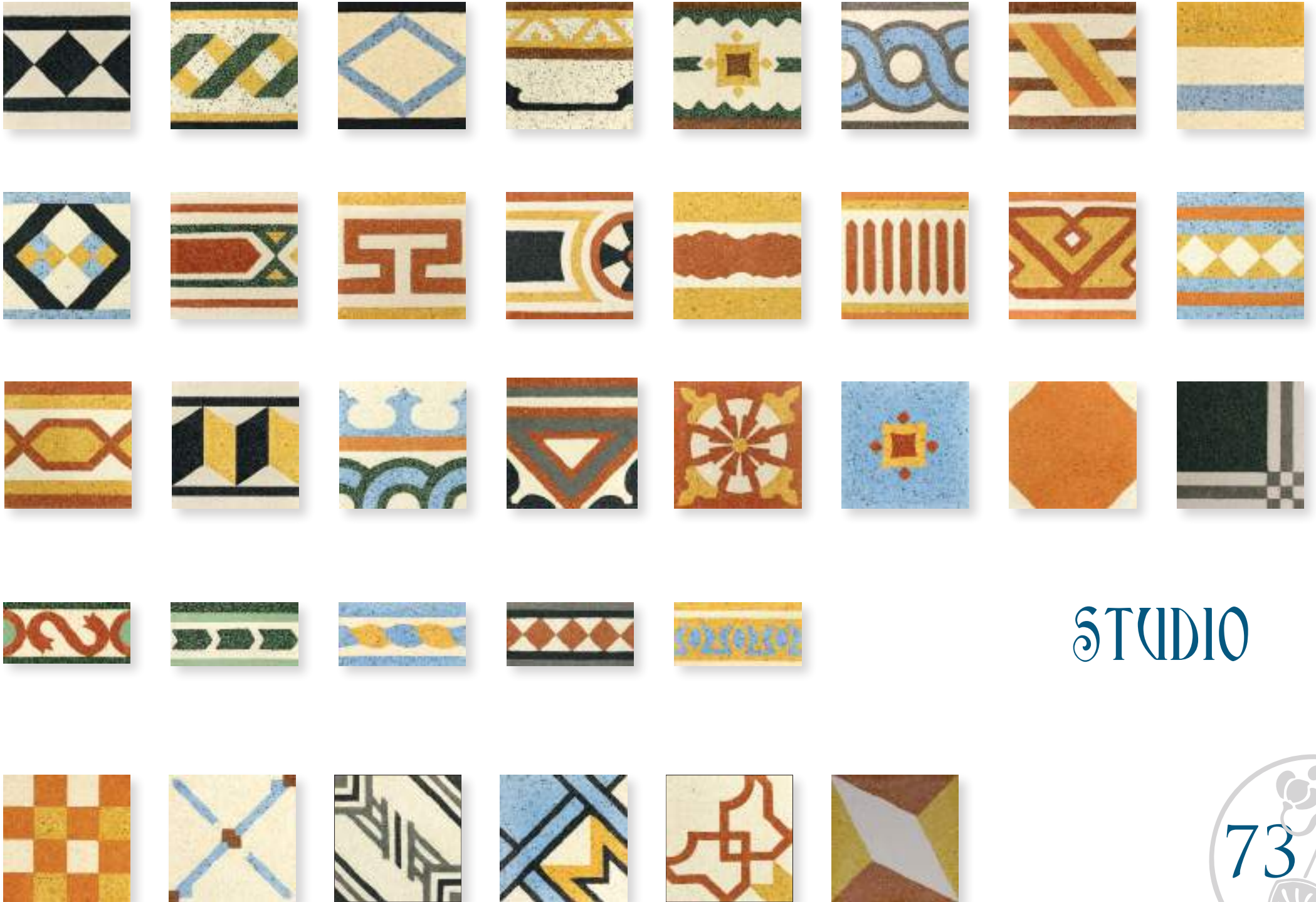

STUDIO

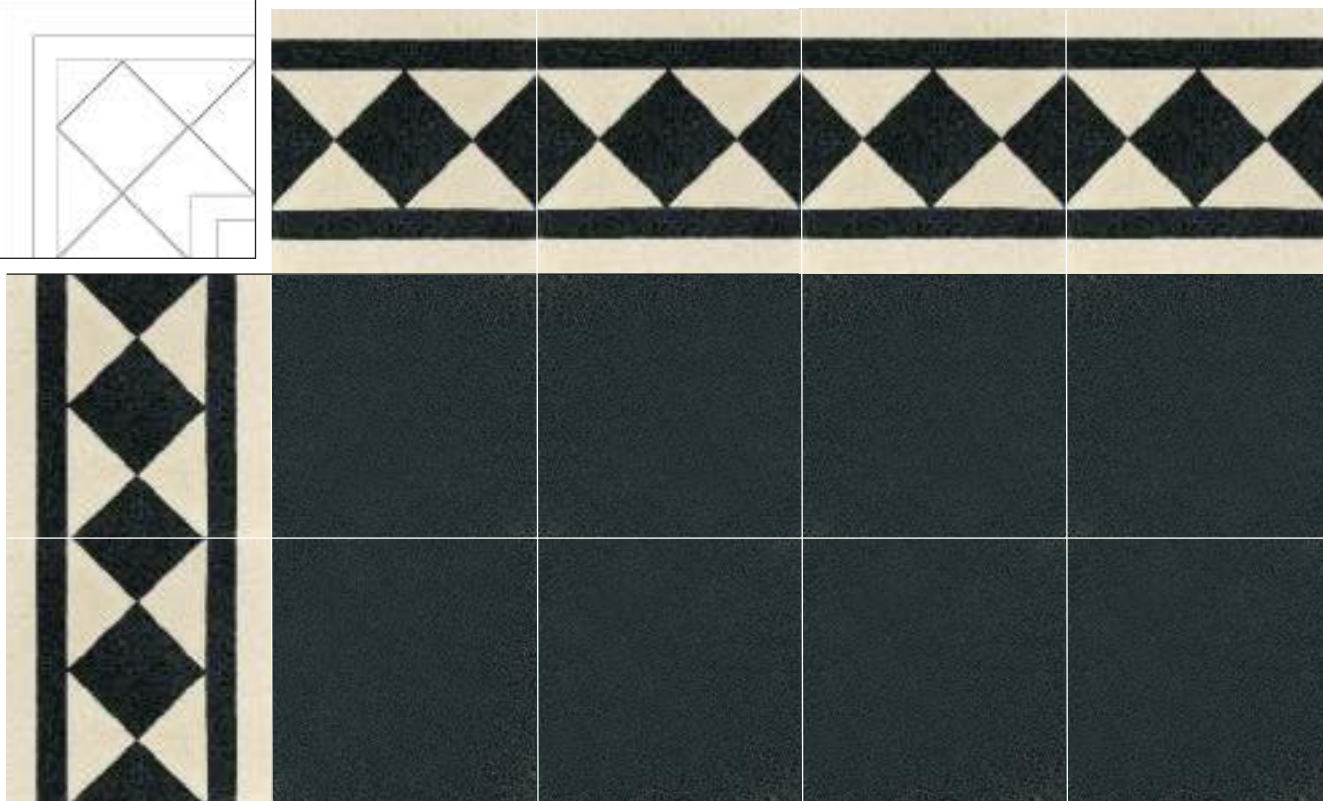
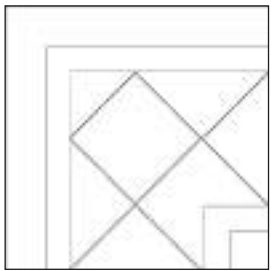

BDS 100

Optical

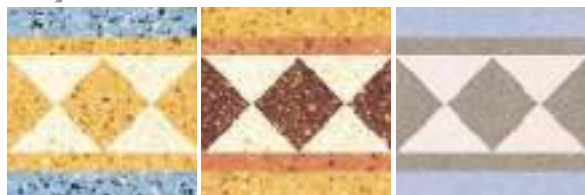

MILLENNIUM





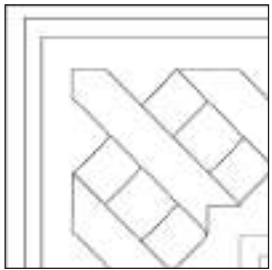

BDS 101

Esperia



MILLENNIUM





formato/format 20x20x1,3 cm

STUDIO Bordure Semplici

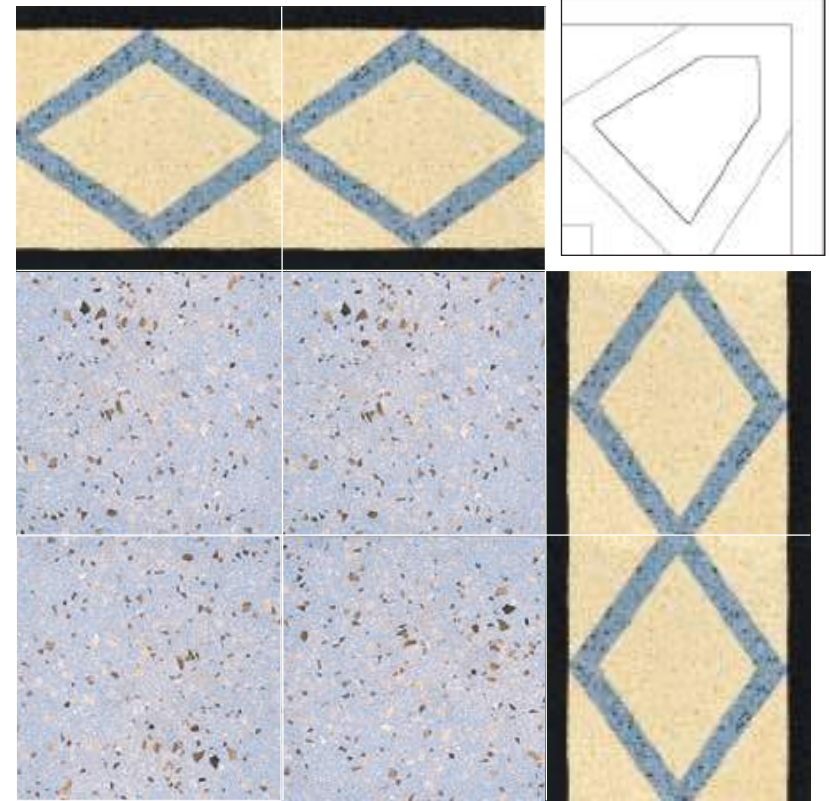

BDS 103

Elirt

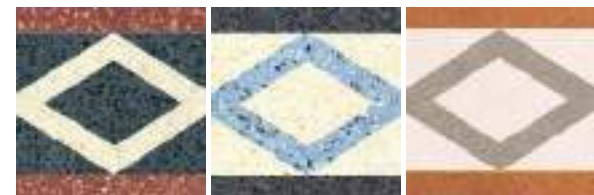

MILLENNIUM



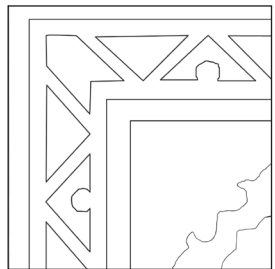

BDS 104

Symbol



MILLENNIUM





formato/format 20x20x1,3 cm

STUDIO Bordure Semplici

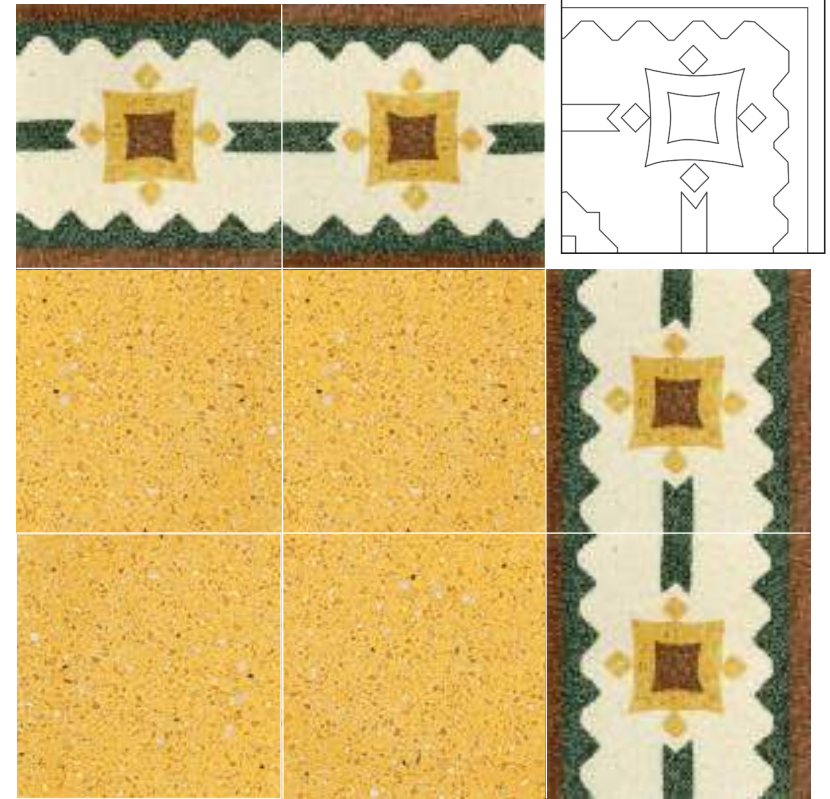

BDS 105

Sultana



MILLENNIUM

79





formato/format 20x20x1,3 cm

STUDIO Bordure Semplici

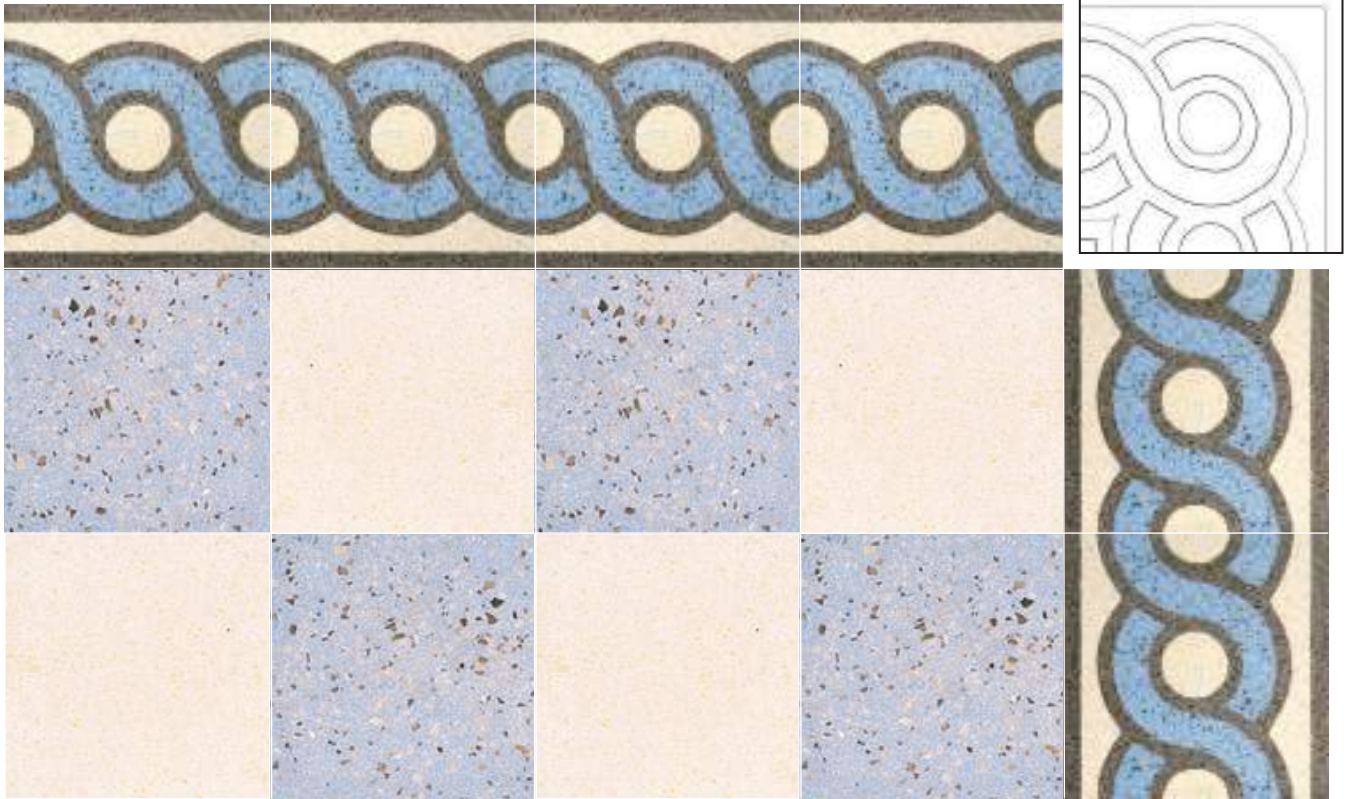

BDS 109



Treccia federiciana



MILLENNIUM



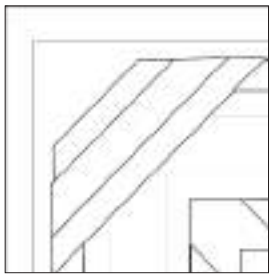

BDS 110

Arazzo



MILLENNIUM

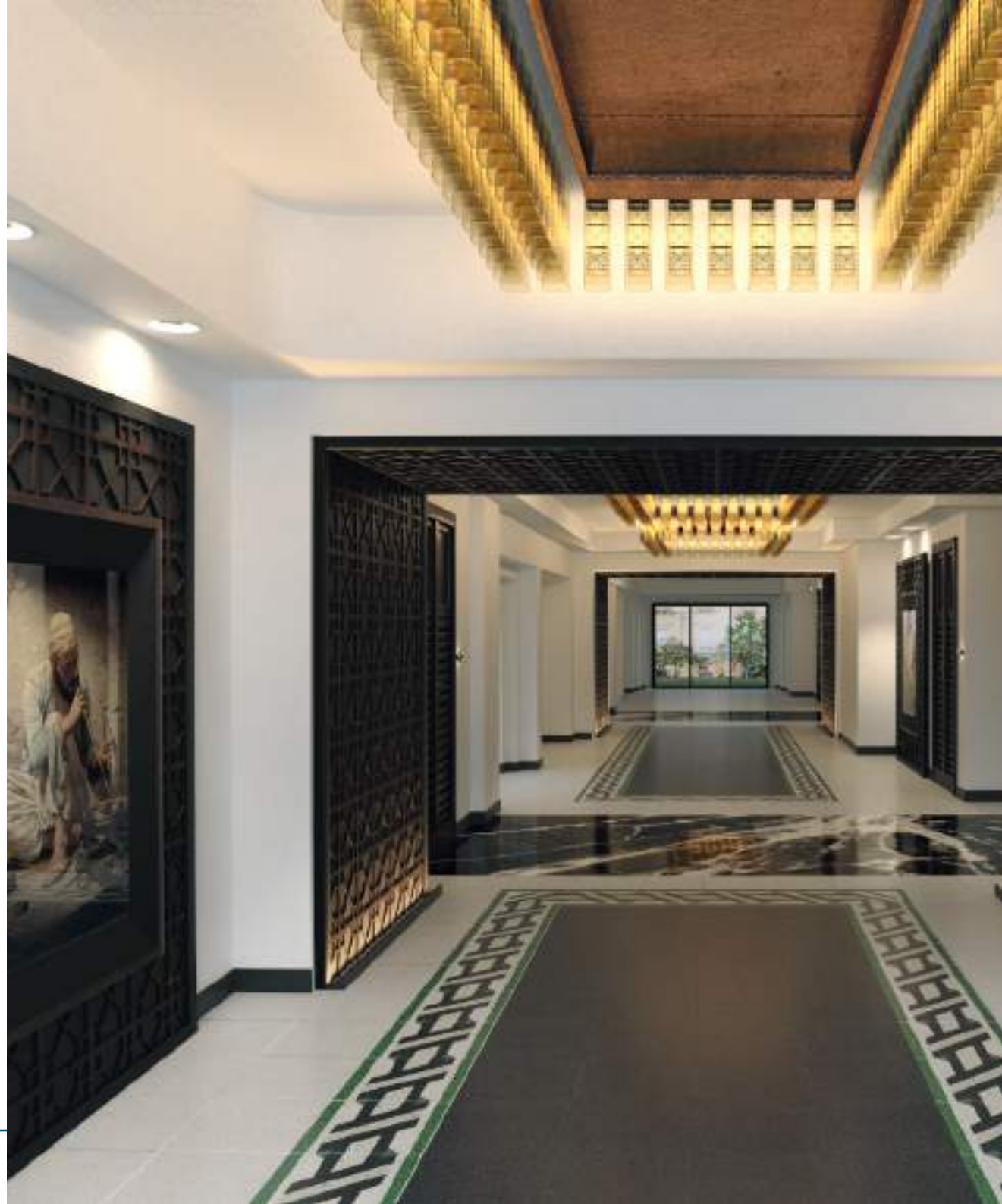



formato/format 20x20x1,3 cm

STUDIO Bordure Semplici

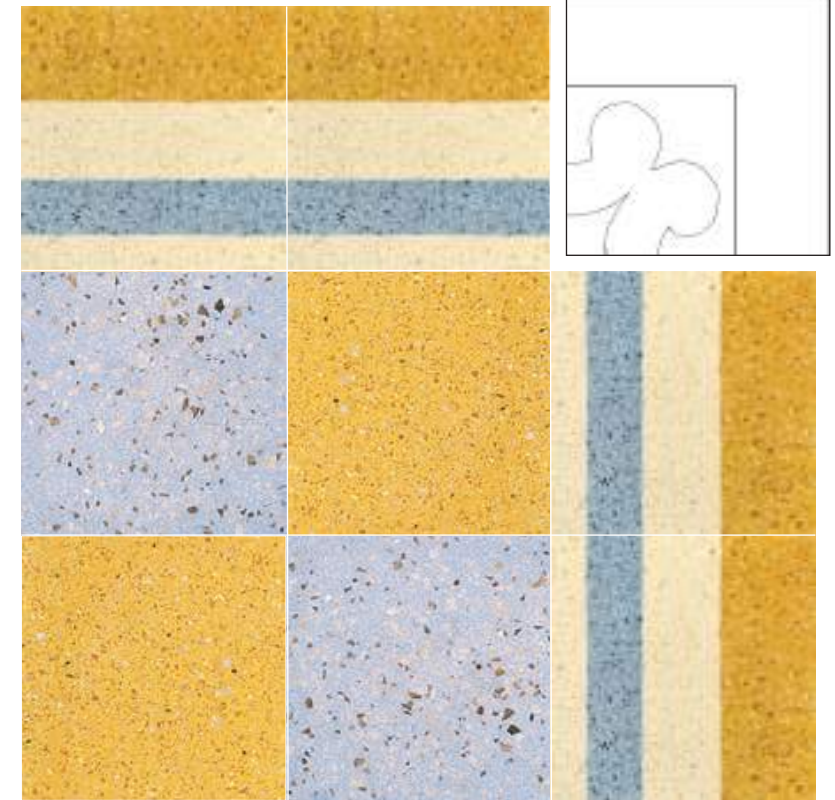

BDS 112

Canne di bamboo

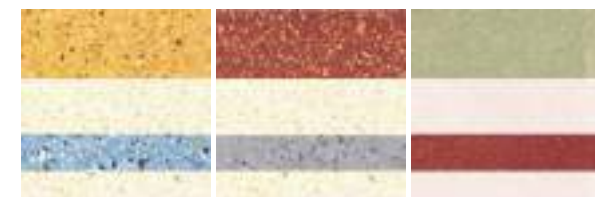

MILLENNIUM





BDS 116

Savoy



MILLENNIUM





formato/format 20x20x1,3 cm

STUDIO Bordure Semplici



*Nella progettazione delle bordure si consiglia di utilizzare un numero dispari di decori per lato, in modo da non interrompere la continuità del disegno.

BDS 119

Oreteia

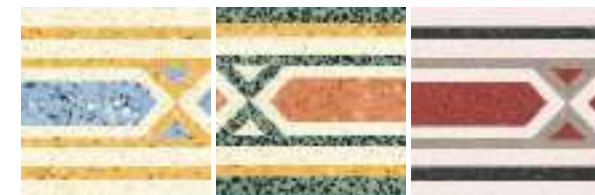

MILLENNIUM



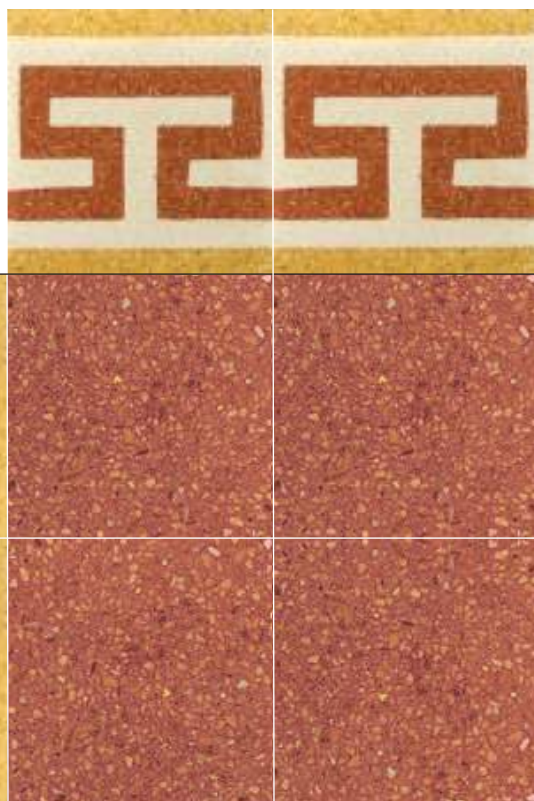
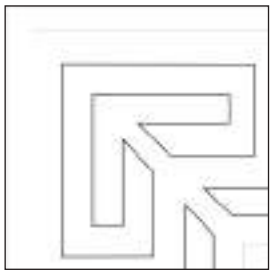

BDS 120

Biondo



MILLENNIUM





formato/format 20x20x1,3 cm

STUDIO Bordure Semplici

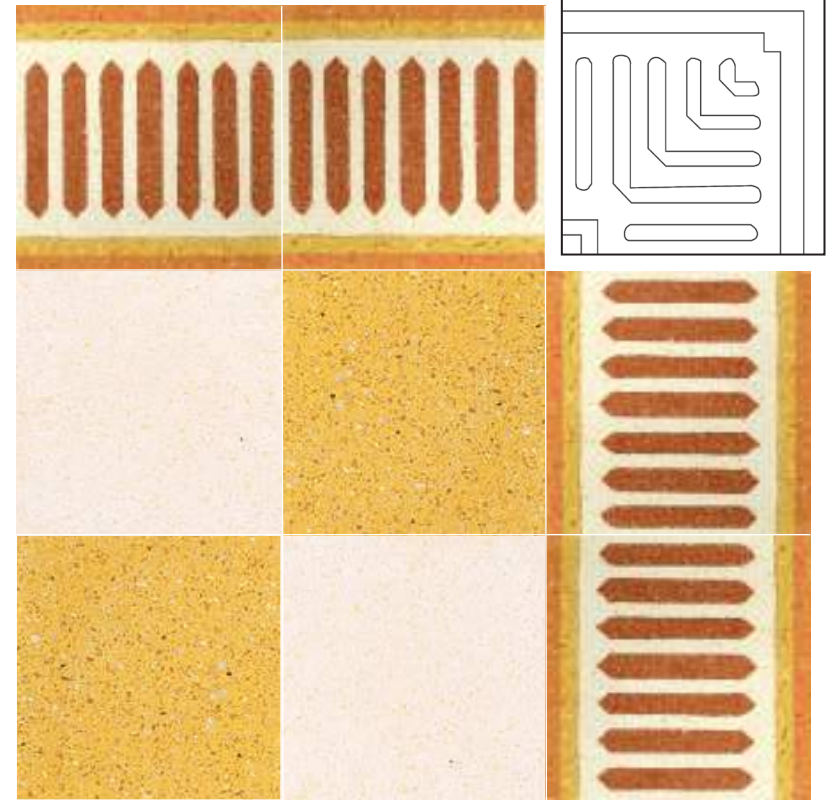

BDS 125

Belmonte

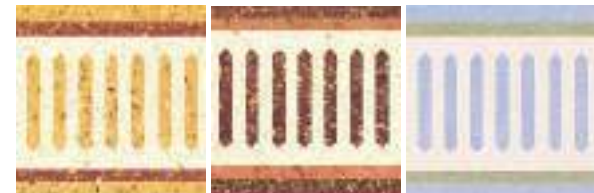

MILLENNIUM





formato/format 20x20x1,3 cm

STUDIO Bordure Semplici



* Nella progettazione delle bordure si consiglia di utilizzare un numero dispari di decori per lato, in modo da non interrompere la continuità del disegno.

* When preparing borders, it is recommended to make use of an odd number of decoration elements on each side so as not to disrupt the continuity of the design

BDS 123

Golia*



MILLENNIUM



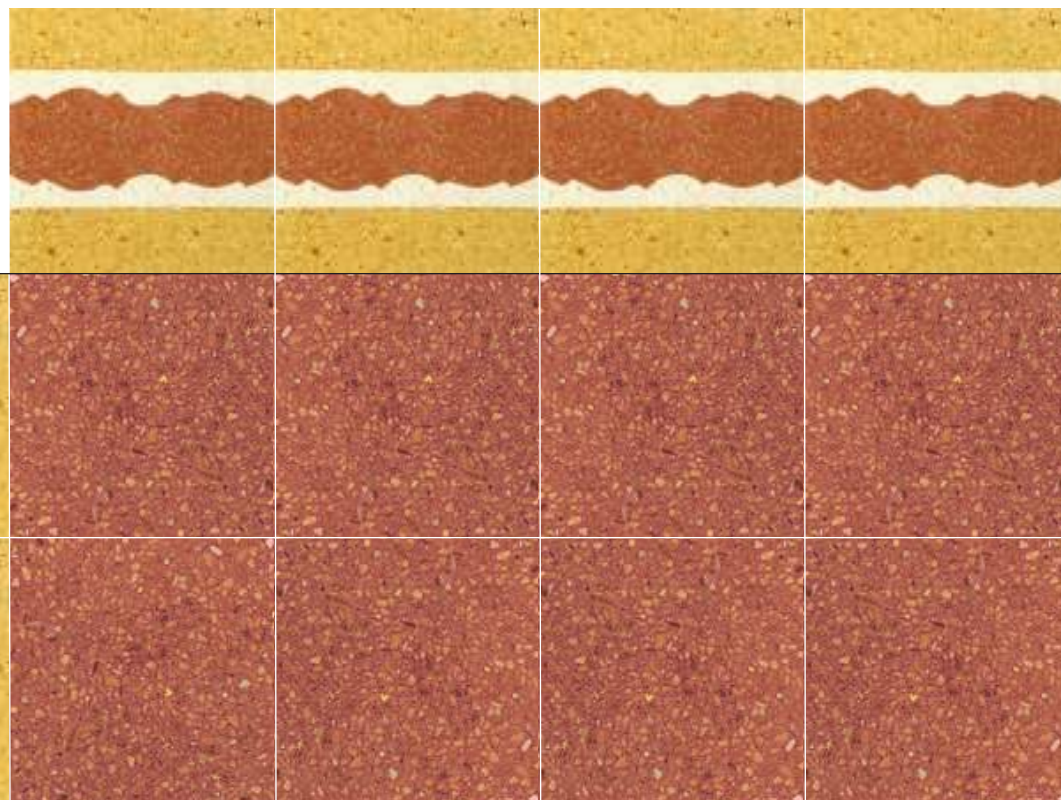
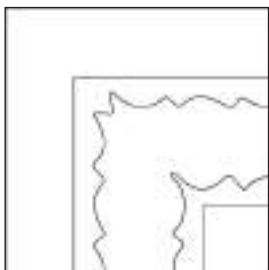

BDS 124

Aegusa

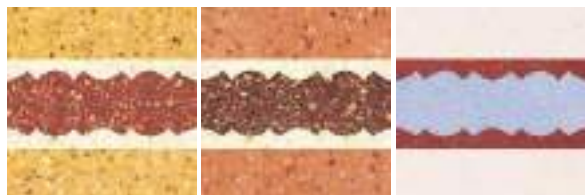

MILLENNIUM





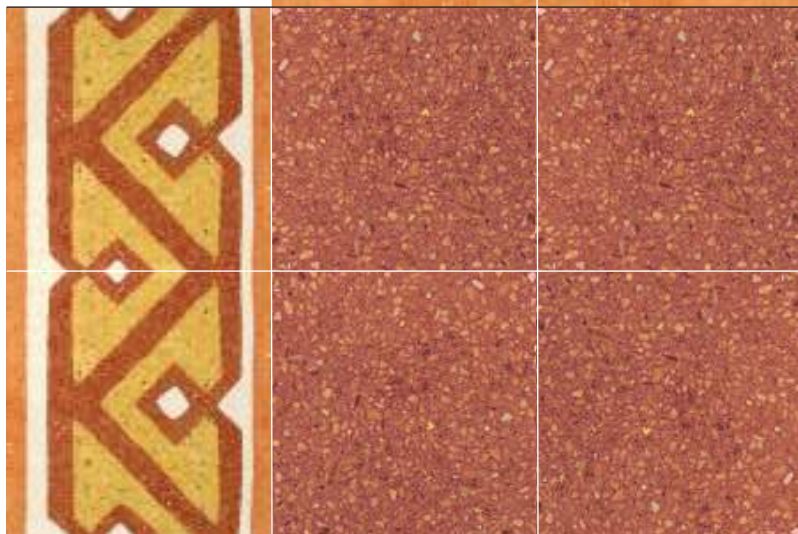
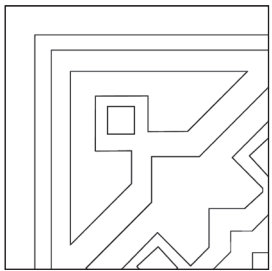

BDS 127

Donna Franca



MILLENNIUM

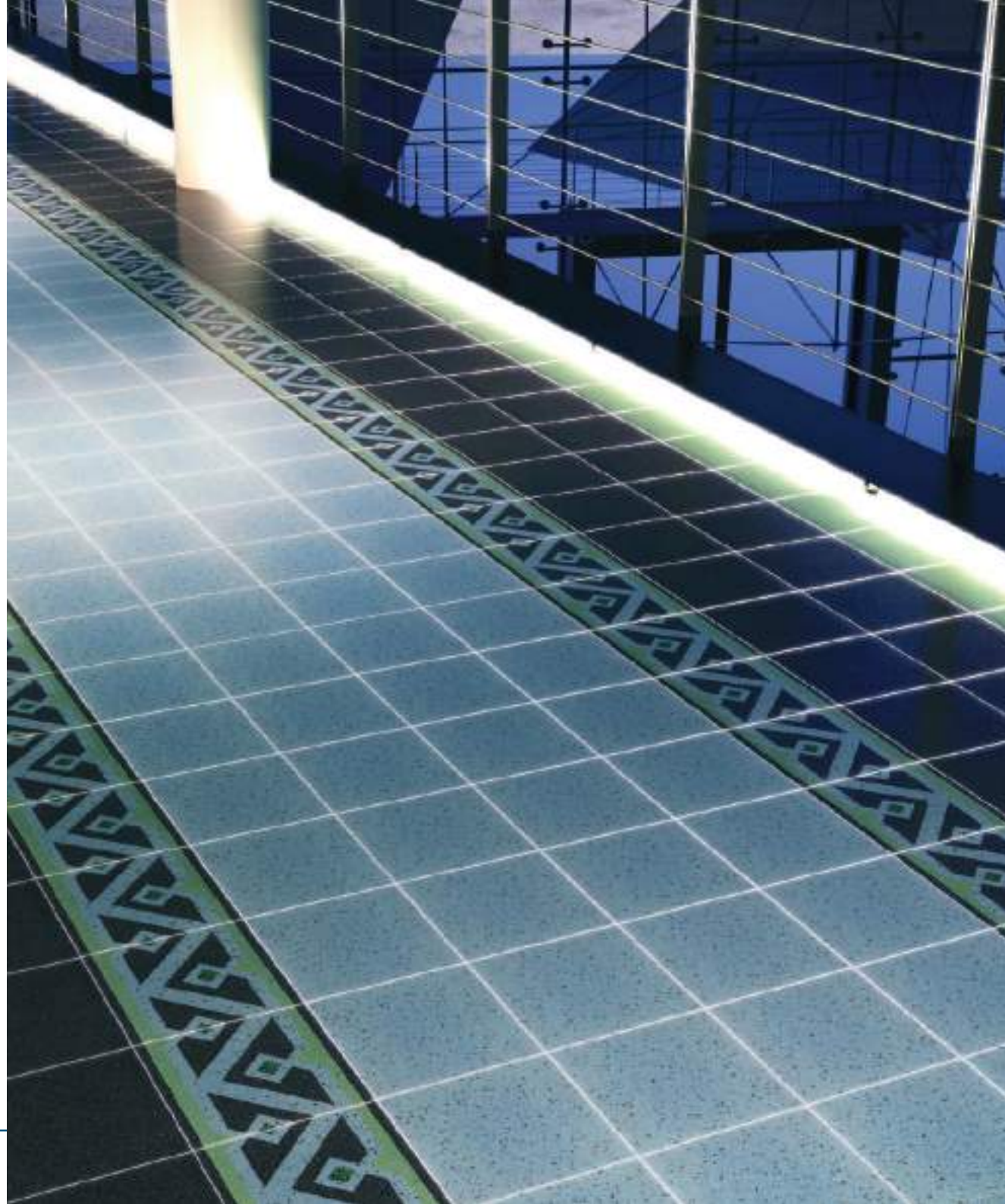



formato/format 20x20x1,3 cm

STUDIO Bordure Semplici

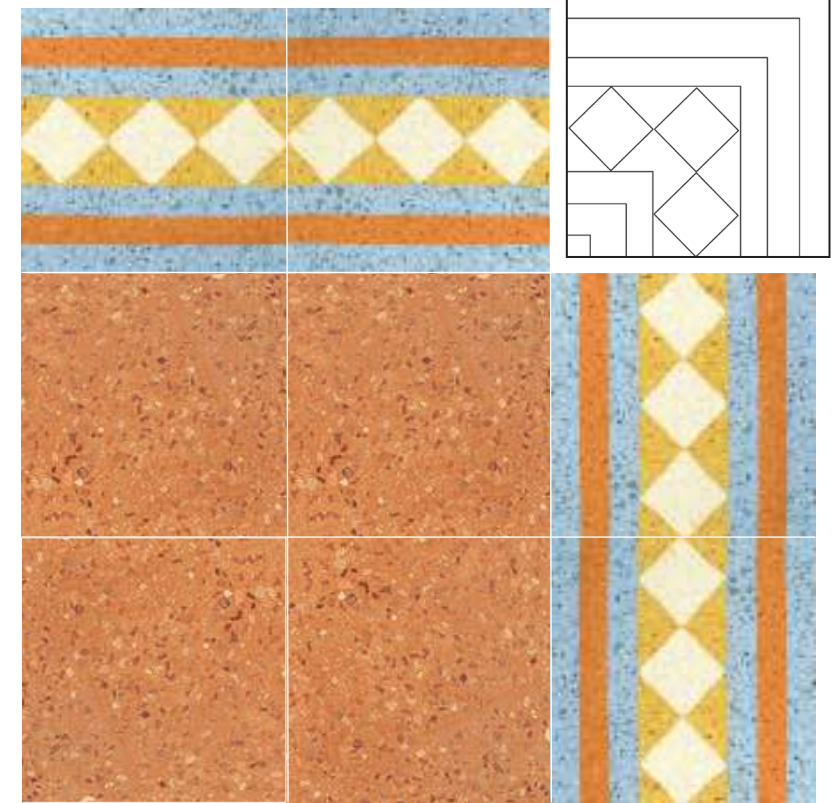

BDS 128

Cassaro

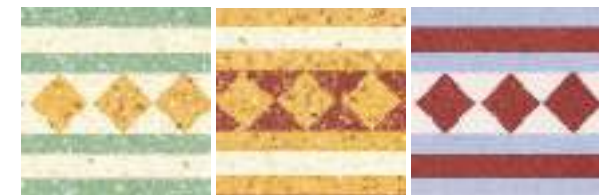

MILLENNIUM



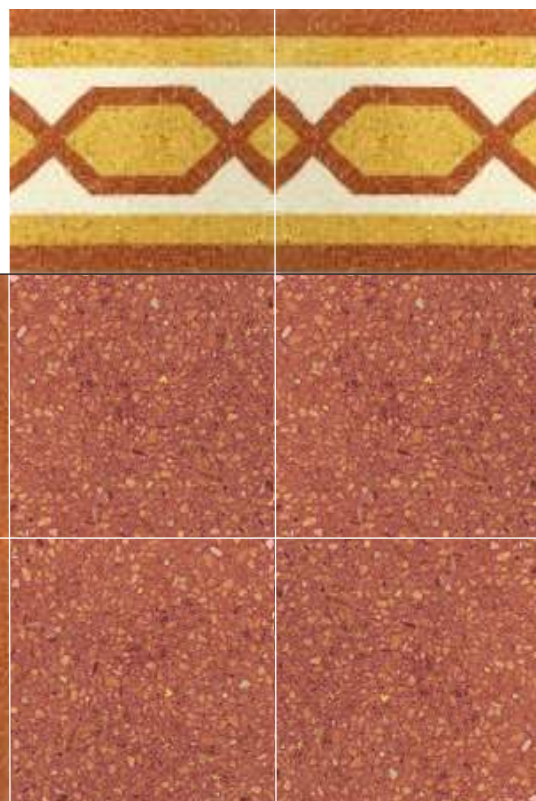
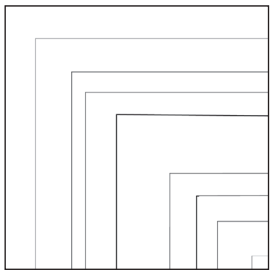

BDS 130

Seralcadio



MILLENNIUM





formato/format 20x20x1,3 cm

STUDIO Bordure Semplici



BDS 132

Cabi prospettici



MILLENNIUM





BDD 200

Olivella



MILLENNIUM





formato/format 20x20x1,3 cm

STUDIO Bordure Doppie



La Marina

BDD 205



MILLENNIUM





FSC 302

Succo d'erba



MILLENNIUM





formato/format 20x10x1,3 cm

STUDIO Fasce

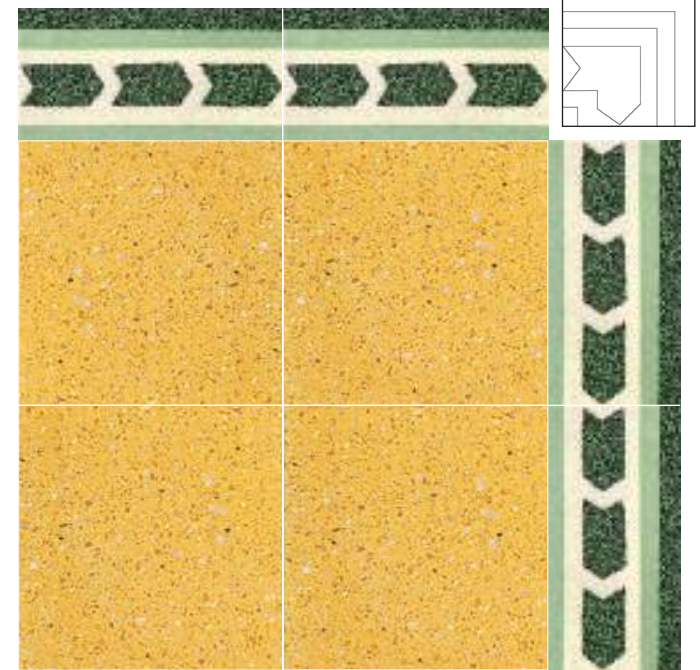

FSC 303

Nave di pietra



MILLENNIUM





formato/format 20x10x1,3 cm

STUDIO Fasce



FSC 305

Hall



MILLENNIUM



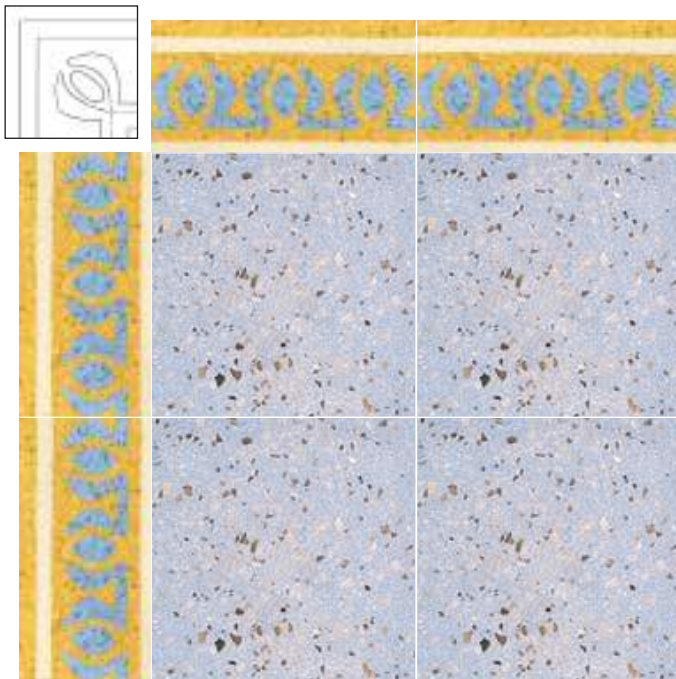

FSC 306

Onda di mare



MILLENNIUM





formato/format 20x10x1,3 cm

STUDIO Fasce

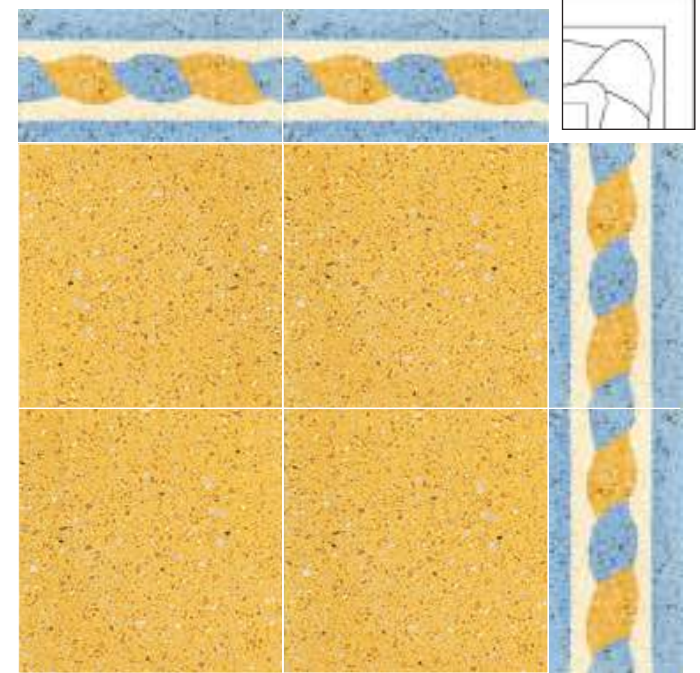

FSC 304

Torchon



MILLENNIUM





DEC 400

Rosa dei venti



MILLENNIUM



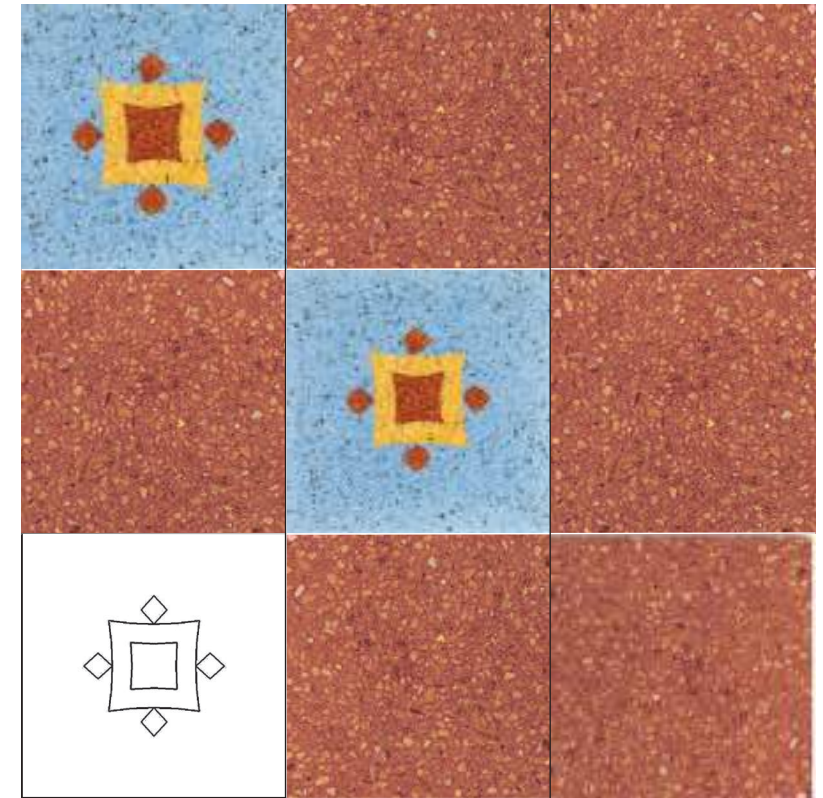

DEC 403

Quattro venti



MILLENNIUM



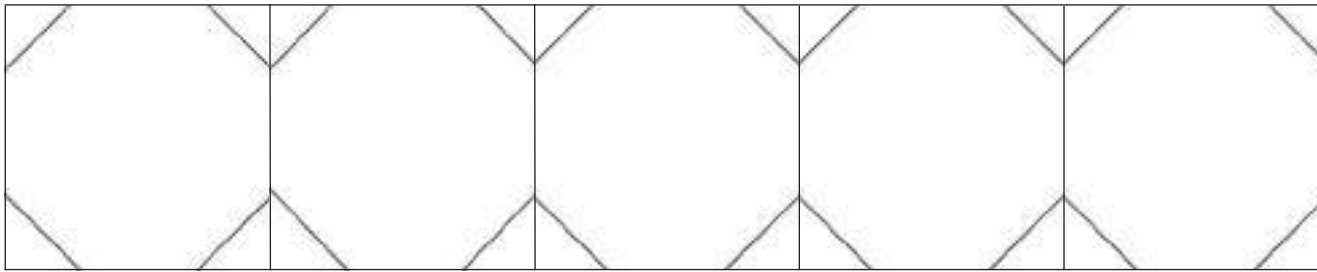
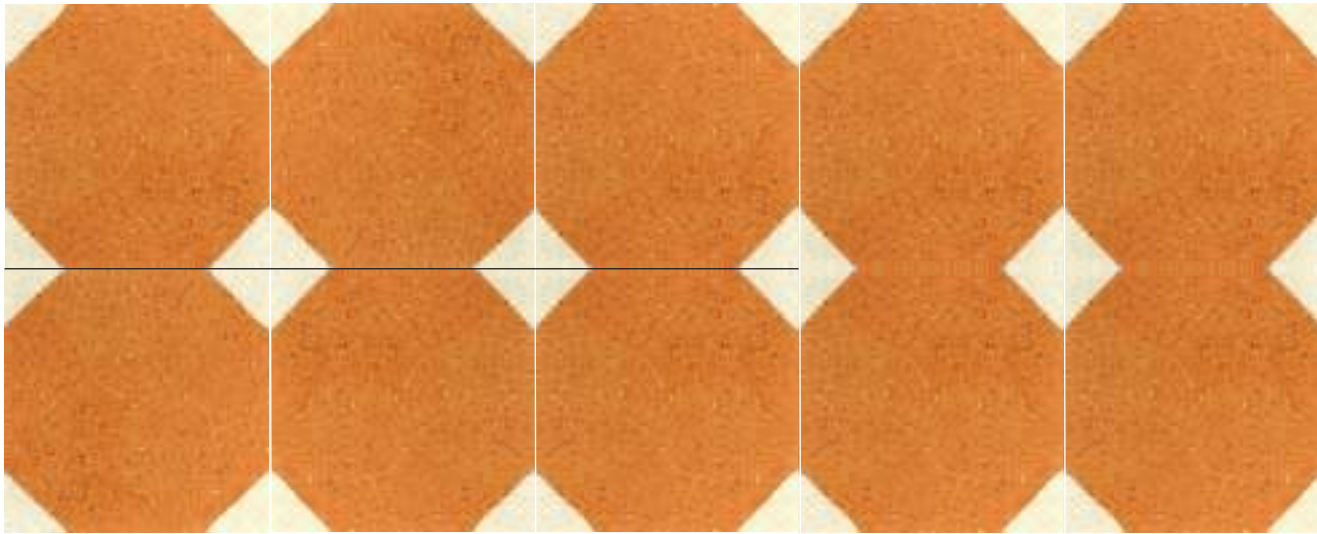

TPT 502

Exagon



MILLENNIUM







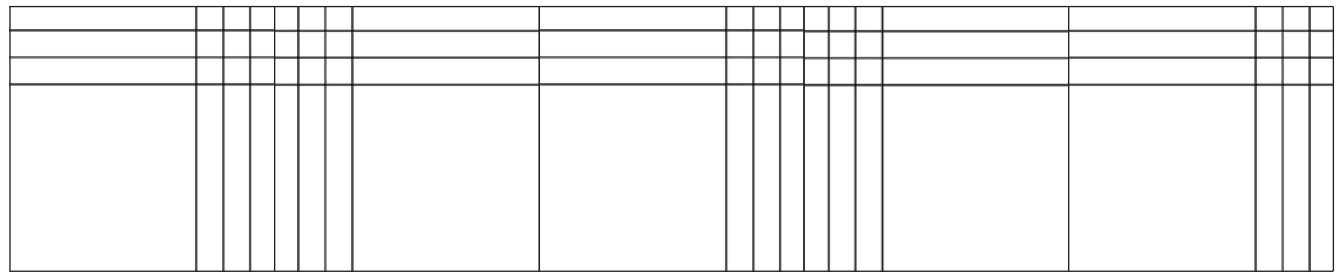
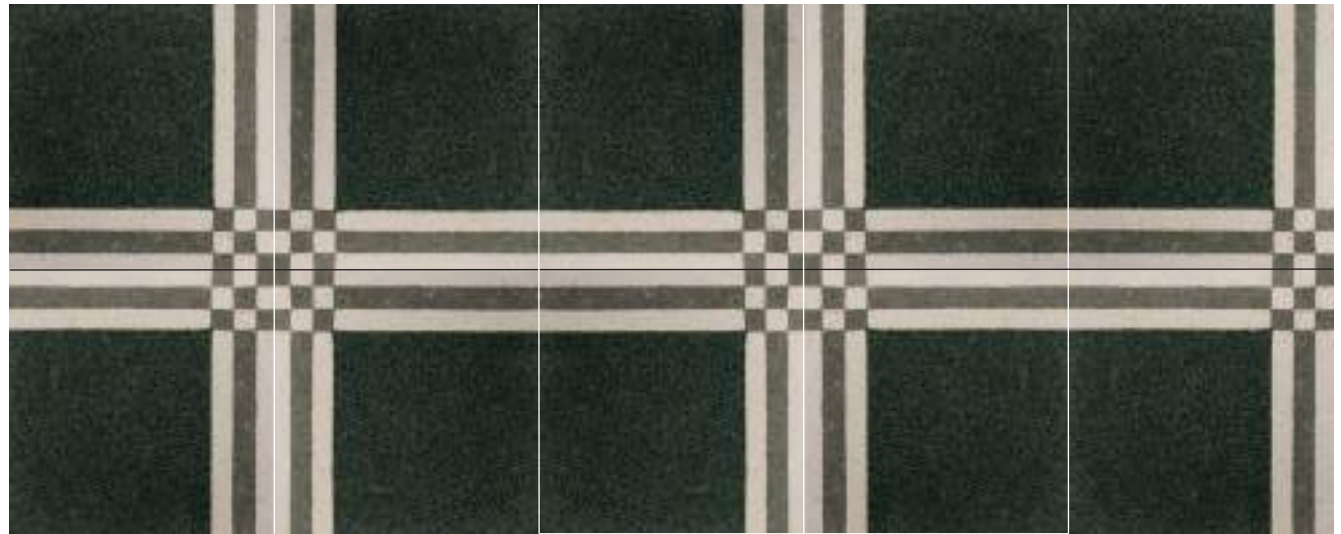

TPT 507



Karsaal



MILLENNIUM



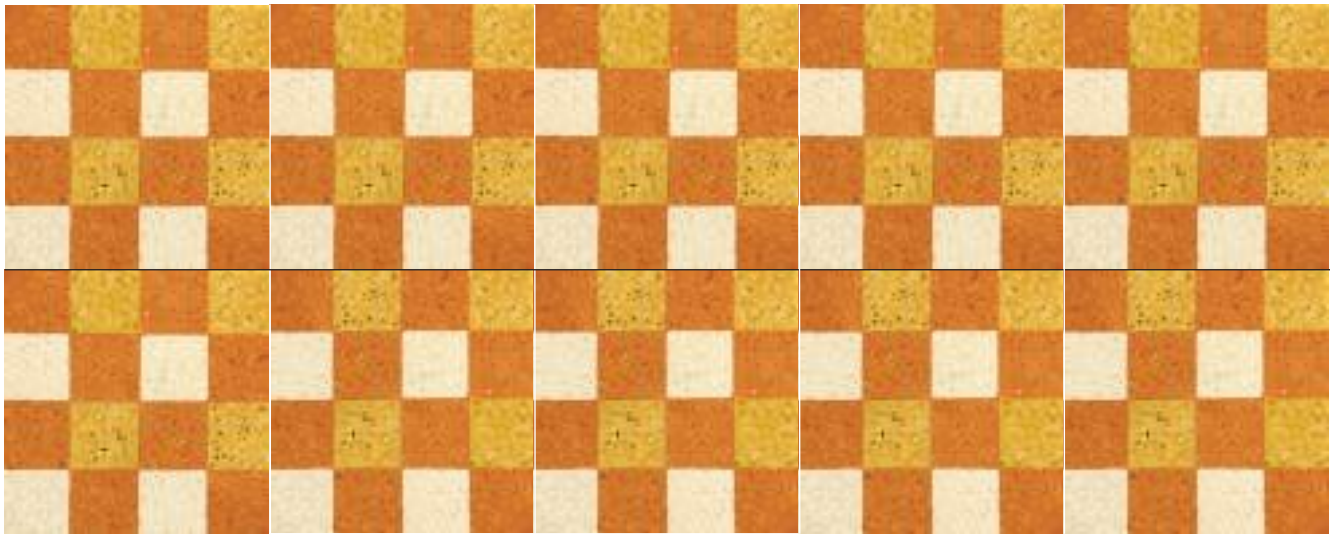

TPT 508

Scacco Matto



MILLENNIUM





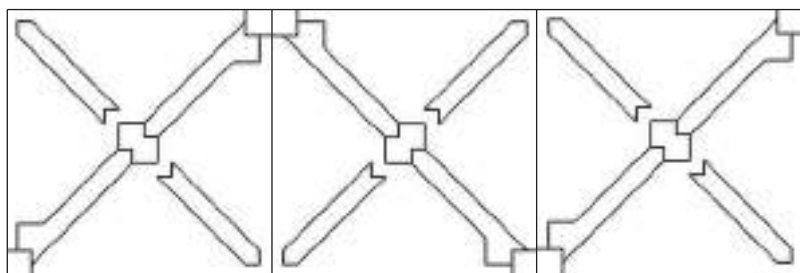
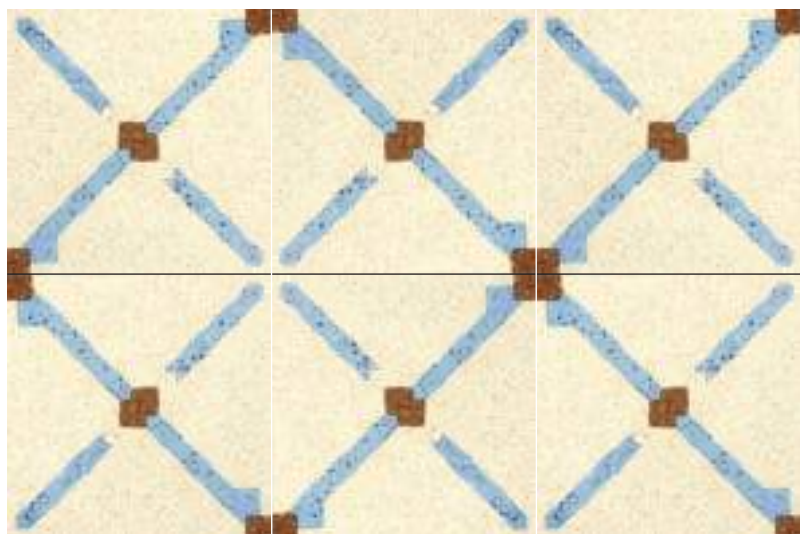

TPT 509

Arsenale



MILLENNIUM



formato/format 20x20x1,3 cm

STUDIO Tappeti

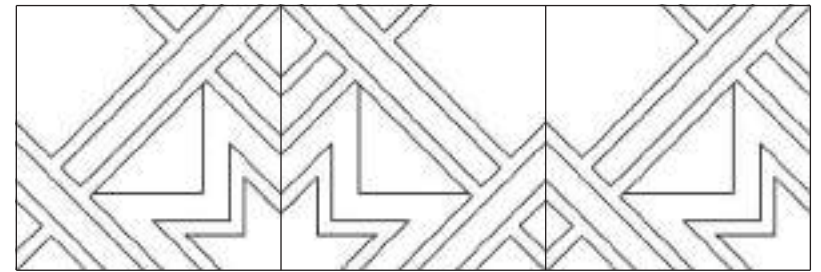

TPT 512

Qanat



MILLENNIUM

113



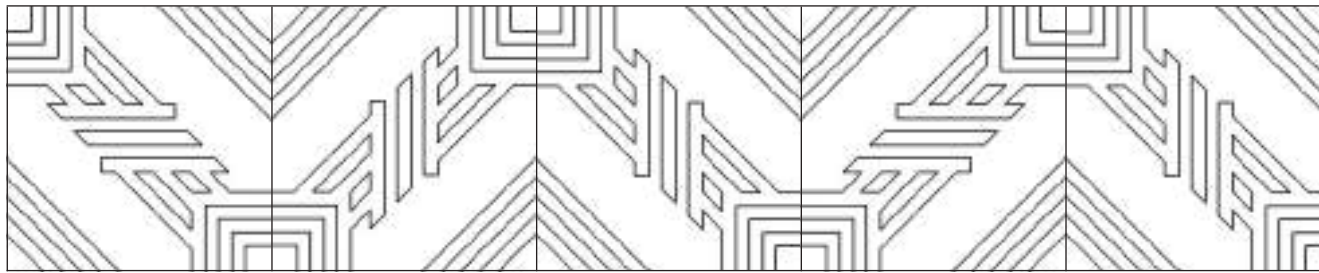

TPT 511

Codex



MILLENNIUM





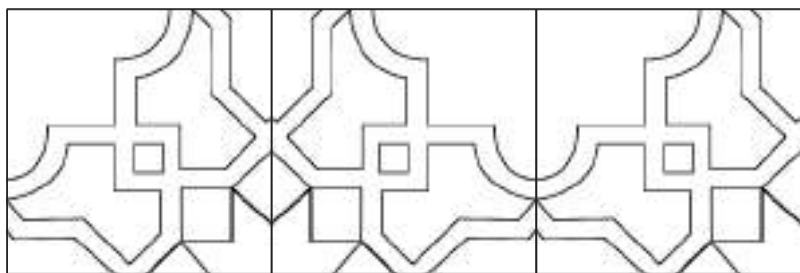
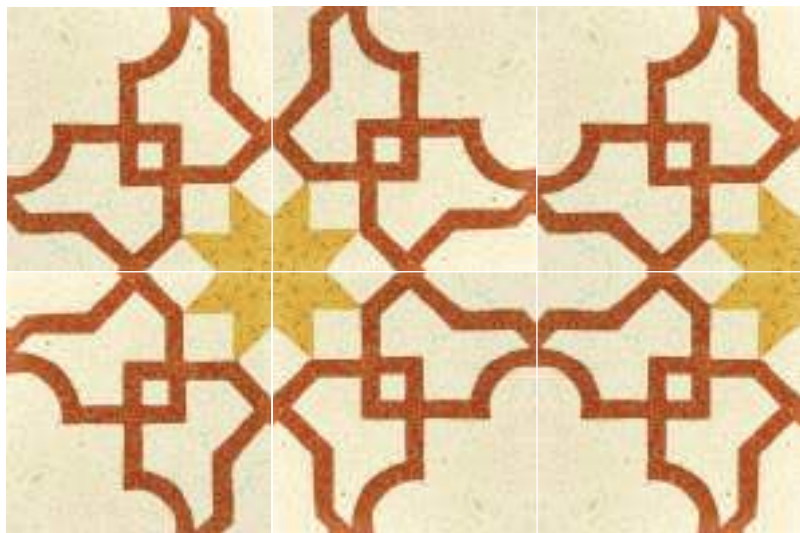

TPT 515

Tarsia



MILLENNIUM

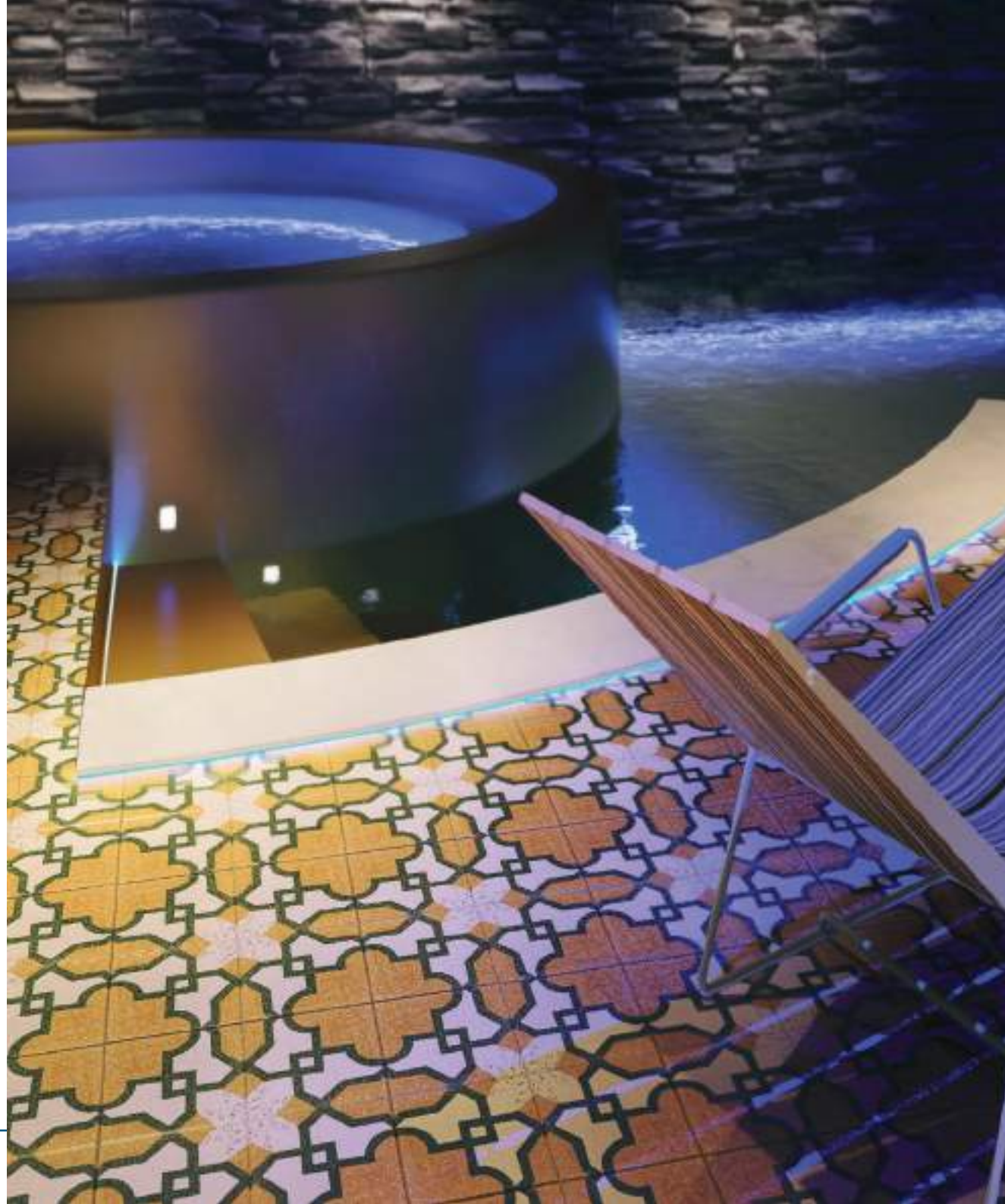

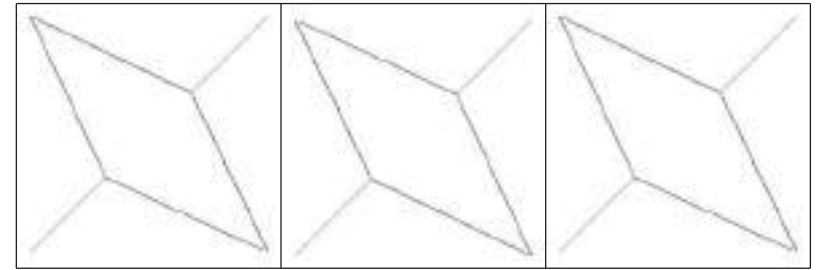
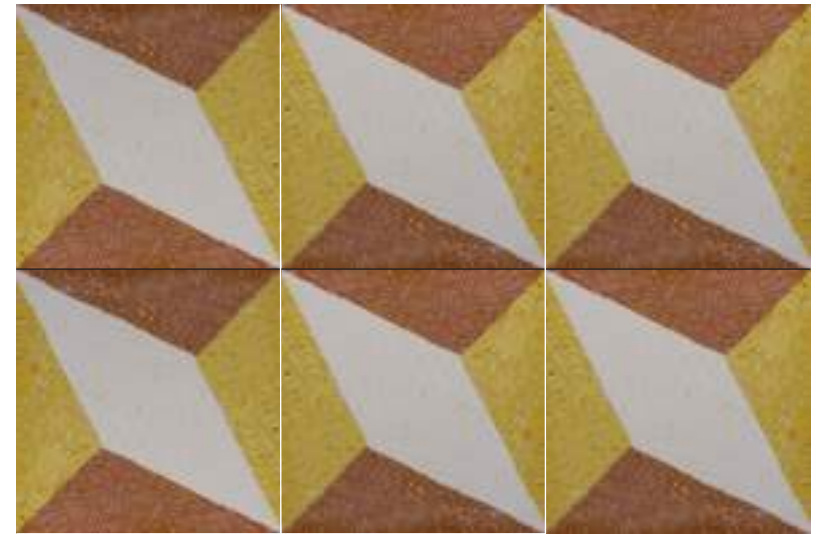

TPT 517

Diamante

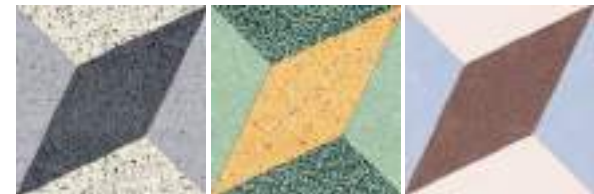

MILLENNIUM





ATLANTIS

>>> CLASSICO



Tendenze attuali, moda e design come fonte d'ispirazione per personalizzare la propria casa con un look grintoso d'effetto. La linea Atlantis propone nuovi decori che nascono da geniali intuizioni dei designers, semplici linee ed elementi geometrici che si riempiono di colori. Contemporaneità ed avanguardia per una linea giovane che sa coniugare tendenze innovative ed esigenze pratiche.

Current trends, fashion and design as the source of inspiration to personalise your home with a gritty look. The Atlantis line offers new patterns, the brilliant insight of designers, simple lines and geometric elements that fill up with colours. Contemporaneity and modernity for a young line that combines innovative trends and practical needs.

FOGAZZA

>> PATCHWORK

GRIGIO



>> grigio - 4pz



>> nero - 3pz



>> bds 100 - 1pz



>> bds 101 - 1pz



>> bds 103 - 1pz



>> bds 105 - 1pz



>> bds 109 - 1pz



>> bds 110 - 1pz



>> bds 116 - 1pz



>> bds 120 - 1pz



>> bds 124 - 1pz

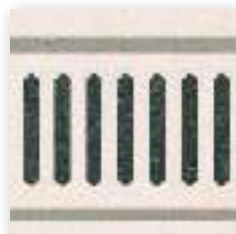

>> bds 125 - 1pz



>> bds 127 - 1pz



>> bds 128 - 1pz

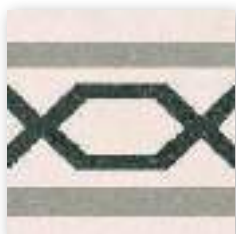

>> bds 130 - 1pz



>> dec 400 - 1pz



>> tpt 502 - 1pz



>> tpt 507 - 1pz



>> tpt 509 - 1pz



>> tpt 511 - 1pz

Un metro quadrato di patchwork è costituito da 7 marmette Tinta Unita e 18 a Decoro
Formato 20x20x1,3 cm
Finitura Anticata (AK)

One square meter of patchwork is composed of 7 Solid colour tiles and 18 Decorated tiles
Format 20x20x1,3 cm
Finish Antique (AK)

120

ATLANTIS



>> PATCHWORK

AZZURRO



>> **grigio** - 4pz



>> **azzurro** - 3pz



>> **bds 100** - 1pz



>> **bds 101** - 1pz



>> **bds 103** - 1pz



>> **bds 105** - 1pz



>> **bds 109** - 1pz



>> **bds 110** - 1pz



>> **bds 116** - 1pz



>> **bds 120** - 1pz



>> **bds 124** - 1pz

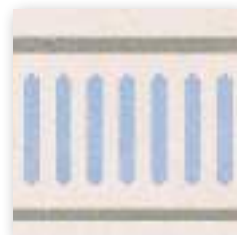

>> **bds 125** - 1pz



>> **bds 127** - 1pz



>> **bds 128** - 1pz



>> **bds 130** - 1pz



>> **dec 400** - 1pz



>> **tpt 502** - 1pz



>> **tpt 507** - 1pz



>> **tpt 509** - 1pz



>> **tpt 511** - 1pz

Un metro quadrato di patchwork è costituito da 7 marmette Tinta Unita e 18 a Decoro

Formato 20x20x1,3 cm

Finitura Anticata (AK)

One square meter of patchwork is composed of 7 Solid colour tiles and 18 Decorated tiles

Format 20x20x1,3 cm

Finish Antique (AK)



>> PATCHWORK

VERDE



>> verdino - 4pz



>> verde - 3pz



>> bds 106 - 1pz



>> bds 107 - 1pz



>> bds 108 - 1pz



>> bds 111 - 1pz



>> bds 113 - 1pz

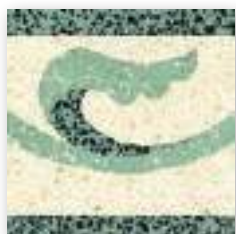

>> bds 115 - 1pz



>> bds 117 - 1pz



>> bds 118 - 1pz



>> bds 121 - 1pz



>> bds 122 - 1pz



>> bds 126 - 1pz



>> bds 129 - 1pz



>> bds 131 - 1pz



>> dec 401 - 1pz



>> dec 402 - 1pz



>> dec 404 - 1pz



>> tpt 501 - 1pz



>> tpt 513 - 1pz

Un metro quadrato di patchwork è costituito da 7 marmette Tinta Unita e 18 a Decoro
Formato 20x20x1,3 cm
Finitura Anticata (AK)

One square meter of patchwork is composed of 7 Solid colour tiles and 18 Decorated tiles
Format 20x20x1,3 cm
Finish Antique (AK)



>> PATCHWORK

GIALLO



>> giallo - 4pz



>> marrone - 3pz



>> bds 106 - 1pz



>> bds 107 - 1pz



>> bds 108 - 1pz



>> bds 111 - 1pz



>> bds 113 - 1pz



>> bds 115 - 1pz



>> bds 117 - 1pz



>> bds 118 - 1pz



>> bds 121 - 1pz



>> bds 122 - 1pz



>> bds 126 - 1pz



>> bds 129 - 1pz



>> bds 131 - 1pz



>> dec 401 - 1pz



>> dec 402 - 1pz



>> dec 404 - 1pz



>> tpt 501 - 1pz



>> tpt 513 - 1pz

Un metro quadrato di patchwork è costituito da 7 marmette Tinta Unita e 18 a Decoro
Formato 20x20x1,3 cm
Finitura Anticata (AK)

One square meter of patchwork is composed of 7 Solid colour tiles and 18 Decorated tiles
Format 20x20x1,3 cm
Finish Antique (AK)



See
the
clock



>> PATCHWORK

MIX COLOR



secondo disponibilità
di magazzino
e richiesta del cliente

subject to availability
of stock and customer demand



PAVON



Marmette in graniglia con disegno composto da due unità. Disponibile in quattro varianti di colori.

Formato 20x20x1,3 cm
Finitura Anticata (AK)

Marble grit flooring tiles with a design made up of two units. Available in four colours

Format 20x20x1,3 cm
Finish Antique (AK)

pavon 01
avorio :: nero :: giallo

pavon 02
nero :: azzurro :: avorio

pavon 03
sabbia :: nero :: azzurro

pavon 04
rosso :: giallo



Marmette in graniglia con disegno composto da una unità.
Disponibile in quattro varianti di colori.

Formato 20x20x1,3 cm
Finitura Anticata (AK)

Marble grit flooring tiles with a design made up of one units.
Available in four colours

Format 20x20x1,3 cm
Finish Antique (AK)



:: wave 01
celestino :: azzurro



:: wave 02
giallino :: giallo

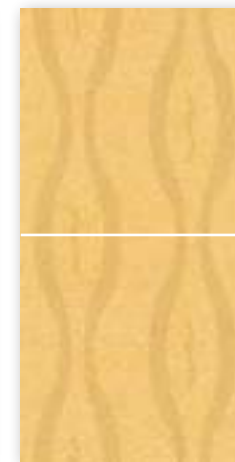

:: wave 03
verdino :: verde



:: wave 04
avorio :: grigio

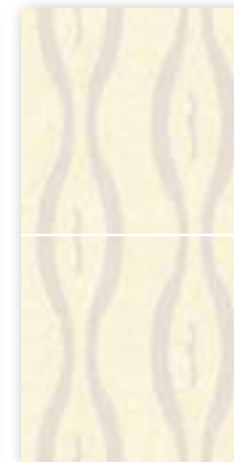

■ SNAKE

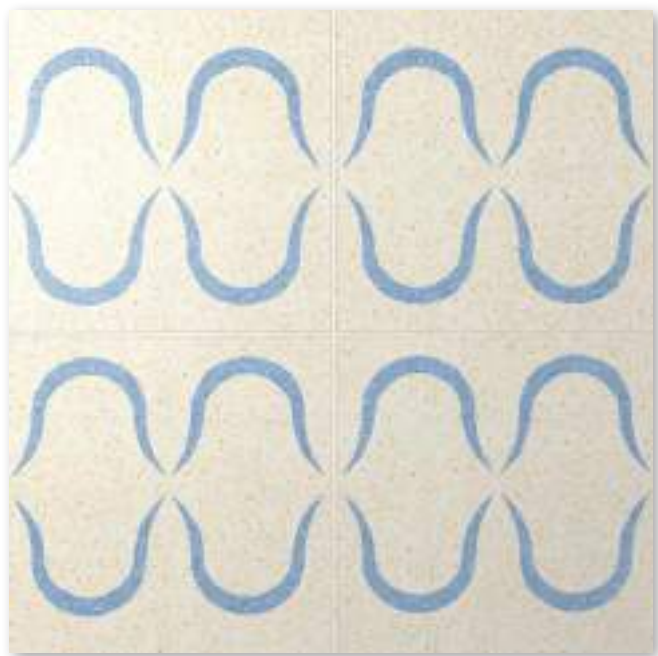

Marmette in graniglia con disegno composto da una unità.
Disponibile in quattro varianti di colori.

Formato 20x20x1,3 cm
Finitura Anticata (AK)

Marble grit flooring tiles with
a design made up of one units.
Available in four colours

Format 20x20x1,3 cm
Finish Antique (AK)

■ snake 01
avorio ■ giallo



■ snake 02
avorio ■ azzurro



■ snake 03
avorio ■ nero



■ snake 04
avorio ■ verde





musiva

500



Formato foglio 23,5x30x1,3 cm
Finitura Anticata (AK) - Lucida (LCD)
Colori in percentuale a scelta.
Formato tessera 2x2 cm

Sheet dimension 23,5x30x1,3 cm
Finish Antique (AK) - Polished (LCD)
Colours in the desired percentage.
Mosaic size 2x2 cm

501



Formato foglio 24,5x28,5x1,3 cm
Finitura Anticata (AK) - Lucida (LCD)
Colori in percentuale a scelta.
Formato tessera 1,5x3 cm

Sheet dimension 24,5x28,5x1,3 cm
Finish Antique (AK) - Polished (LCD)
Colours in the desired percentage.
Mosaic size 1,5x3 cm

502



Formato foglio 22x30x1,3 cm
Finitura Anticata (AK) - Lucida (LCD)
Colori in percentuale a scelta.
Formato tessera 2x4 cm

Sheet dimension 22x30x1,3 cm
Finish Antique (AK) - Polished (LCD)
Colours in the desired percentage.
Mosaic size 2x4 cm



musiva

503



Formato foglio 21,5x28,5x1,3 cm
Finitura Anticata (AK) - Lucida (LCD)
Colori in percentuale a scelta.
Formato tessera 3x3cm

Sheet dimension 21,5x28,5x1,3 cm
Finish Antique (AK) - Polished (LCD)
Colours in the desired percentage.
Mosaic size 3x3 cm

504



Formato foglio 24,5x28,5x1,3 cm
Finitura Anticata (AK) - Lucida (LCD)
Colori in percentuale a scelta.
Formato tessera 3x6 cm

Sheet dimension 24,5x28,5x1,3 cm
Finish Antique (AK) - Polished (LCD)
Colours in the desired percentage.
Mosaic size 3x6 cm

505



Formato foglio 22x30x1,3 cm
Finitura Anticata (AK) - Lucida (LCD)
Colori in percentuale a scelta.
Formato tessera 4x4 cm

Sheet dimension 22x30x1,3 cm
Finish Antique (AK) - Polished (LCD)
Colours in the desired percentage.
Mosaic size 4x4 cm



...WOODSTONE *naturale*



... naturale • antracite

Materiale Graniglia
Formato (cm) 40x40 - 40x20 - 40x10 - 20x10 - 10x10
Spessore (cm) 1,8
Finitura Decapè (DCP)



... naturale • crema

Material Graniglia
Format (cm) 40x40 - 40x20 - 40x10 - 20x10 - 10x10
Thickness (cm) 1,8
Finish Decapè (DCP)



... naturale • grigio



...WOODSTONE *naturale*



... naturale • marrone

Materiale Graniglia

Formato (cm) 40x40 - 40x20 - 40x10 - 20x10 - 10x10

Spessore (cm) 1,8

Finitura Decapè (DCP)



... naturale • nero

Material Graniglia

Format (cm) 40x40 - 40x20 - 40x10 - 20x10 - 10x10

Thickness (cm) 1,8

Finish Decapè (DCP)



... naturale • salmone

140

ATLANTIS





...WOODSTONE *pastello*



... pastello • arancio

Materiale Graniglia
Formato (cm) 40x40 - 40x20 - 40x10 - 20x10 - 10x10
Spessore (cm) 1,8
Finitura Decapè (DCP)



... pastello • azzurro

Material Graniglia
Format (cm) 40x40 - 40x20 - 40x10 - 20x10 - 10x10
Thickness (cm) 1,8
Finish Decapè (DCP)



... pastello • fragola



...WOODSTONE *pastello*



... pastello • glicine

Materiale Graniglia
Formato (cm) 40x40 - 40x20 - 40x10 - 20x10 - 10x10
Spessore (cm) 1,8
Finitura Decapè (DCP)



... pastello • limone

Material Graniglia
Format (cm) 40x40 - 40x20 - 40x10 - 20x10 - 10x10
Thickness (cm) 1,8
Finish Decapè (DCP)

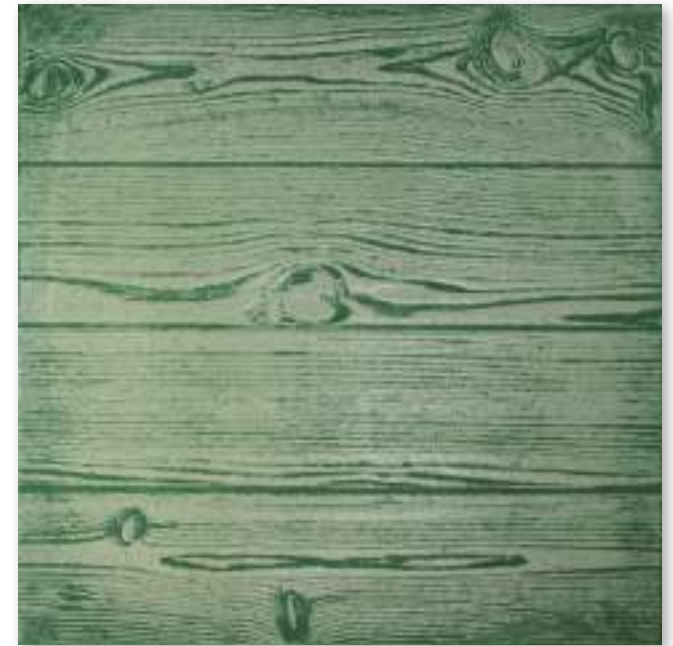

... pastello • verde





146
ma

HAUTE COUTURE

>>> SU MISURA

Andare sempre alla ricerca di un'originalità che contraddistingue, sperimentare il lusso di una linea haute couture per la propria casa. Materiali d'élite incontrano la graniglia, la linea Haute Couture si propone di realizzare rivestimenti all'avanguardia dal design ricercato per vestire le superfici con forme e colori esclusivi ed eccentrici.

A causa delle loro peculiarità, la fornitura di queste collezioni va concordata con l'ufficio vendite.

Always looking for an originality that sets us apart, to experience the luxury of haute couture in your home. Elite materials meet graniglia, the Haute Couture line aims to create cutting-edge tiling designed to dress the surfaces with exclusive and eccentric shapes and colours.

Due to their particular features, customers need to arrange shipment of these collections with our sales department.

FOGAZZA

147
m. dam

ART NOUVEAU



BAUHAUS

Formato • Format
25x25x1,4 cm
Finitura • Finish
Lucida (LCD)
Polished (LCD)



giallo

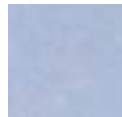

azzurro

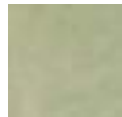

verdino



LIBERTY

Formato • Format
25x25x1,4 cm
Finitura • Finish
Lucida (LCD)
Polished (LCD)



giallo



antracite

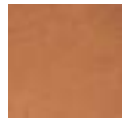

salmone



DAMASCO

Formato • Format
25x25x1,4 cm
Finitura • Finish
Lucida (LCD)
Polished (LCD)



grigio



rosso



sabbia



TIFFANY

Formato • Format
25x25x1,4 cm
Finitura • Finish
Lucida (LCD)
Polished (LCD)



giallo

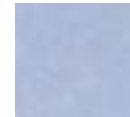

azzurro

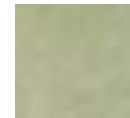

verdino

148

malcom



ORIGAMI



KATANA • 01

Formato • Format
40x40x2 cm
Materiale • Material
Graniglia e Acciaio
Marble Grift and Steel
Finitura • Finish
Lucida (LCD)
Polished (LCD)



KATANA • 02

Formato • Format
40x40x2 cm
Materiale • Material
Graniglia e Acciaio
Marble Grift and Steel
Finitura • Finish
Lucida (LCD)
Polished (LCD)



KATANA • 03

Formato • Format
40x40x2 cm
Materiale • Material
Graniglia e Acciaio
Marble Grift and Steel
Finitura • Finish
Lucida (LCD)
Polished (LCD)



GONG • 01

Formato • Format
40x40x2 cm
Materiale • Material
Graniglia e Ottone
Marble Grift and Brass
Finitura - Finish
Lucida (LCD)
Polished (LCD)



GONG • 02

Formato - Format
40x40x2 cm
Materiale • Material
Graniglia e Ottone
Marble Grift and Brass
Finitura • Finish
Lucida (LCD)
Polished (LCD)



GONG • 03

Formato - Format
40x40x2 cm
Materiale • Material
Graniglia e Ottone
Marble Grift and Brass
Finitura • Finish
Lucida (LCD)
Polished (LCD)



TATAMI • 01

Formato • Format
40x40x2 cm
Materiale • Material
Graniglia e Legno
Marble Grift and Wood
Finitura • Finish
Lucida (LCD)
Polished (LCD)



TATAMI • 02

Formato • Format
40x40x2 cm
Materiale • Material
Graniglia e Legno
Marble Grift and Wood
Finitura • Finish
Lucida (LCD)
Polished (LCD)



TATAMI • 03

Formato - Format
40x40x2 cm
Materiale • Material
Graniglia e Legno
Marble Grift and Wood
Finitura • Finish
Lucida (LCD)
Polished (LCD)

150

malcom



TASSELLI



[TSL](#) • 1000

Formato • Format

20x20x1,3 cm

Colori • Colours

Tabella Graniglia e Pastina
Graniglia and Pastina Chart

Finitura • Finish

Anticata • Antique (AK)
Lucida • Polished (LCD)



[TSL](#) • 1001

Formato • Format

20x20x1,3 cm

Colori • Colours

Tabella Graniglia e Pastina
Graniglia and Pastina Chart

Finitura • Finish

Anticata • Antique (AK)
Lucida • Polished (LCD)



[TSL](#) • 1002

Formato • Format

20x20x1,3 cm

Colori • Colours

Tabella Graniglia e Pastina
Graniglia and Pastina Chart

Finitura • Finish

Anticata • Antique (AK)
Lucida • Polished (LCD)



[TSL](#) • 1003

Formato • Format

20x20x1,3 cm

Colori • Colours

Tabella Graniglia e Pastina
Graniglia and Pastina Chart

Finitura • Finish

Anticata • Antique (AK)
Lucida • Polished (LCD)

152

Enalcom



SCOPPIATI



Grigio



Marrone



Avorio



Rosato



Celeste



Salmone



Giallo



Verdino

SCOPPIATI

Formato • Format

10x33,3x2,8 cm
3,5x33,3x2,8 cm

Finitura • Finish

A vista
Rough

154

malcom





ACCESSORI ACCESSORIES

>>> FINITURE

Gli Accessori sono elementi in graniglia che completano i vostri progetti, battiscopa, cornici, pedate che rifiniscono le vostre creazioni.

The Accessori are items in graniglia that complete your projects, baseboards, frames, stair treads that add the finishing touch to your creations.

FOGAZZA

CORNIC ZOCOLI FRAMES SKIRTING



ACS.800

GRADINO

Formato • Format

4x20x2,5 cm

Materiale • Material

Graniglia

Finitura • Finish

Lucida (LCD)

Polished (LCD)



ACS.802

LONDON

Formato • Format

4x20x2,5 cm

Materiale • Material

Graniglia

Finitura • Finish

Lucida (LCD)

Polished (LCD)



ACS.801

TORELLO

Formato • Format

2,5x20x2,5 cm

Materiale • Material

Graniglia

Finitura • Finish

Lucida (LCD)

Polished (LCD)



ACS.803

MATITA

Formato • Format

2,5x20x1,3 cm

Materiale • Material

Graniglia

Finitura • Finish

Lucida (LCD)

Polished (LCD)



ACS.800

BOISERIE

Formato • Format

9,5x420x2,5 cm

Materiale • Material

Graniglia

Finitura • Finish

Lucida (LCD)

Polished (LCD)

158

ACCESSORI
ACCESSORIES



BATTISCOPA SKIRTING GRADINO STEP



ACS•805-807

NORMALE | STANDARD

Formato • Format

7,5x20x1,3 cm

Materiale • Material

ACS•805A Graniglia | **ACS•807A** Pastina

Finitura • Finish

Anticata (AK) | Lucida (LCD)

Antique (AK) | Polished (LCD)



ACS•806-808

MEZZO TORO | HALF TORUS

Formato • Format

2,5x20x2,5 cm

Materiale • Material

ACS•806A Graniglia | **ACS•808A** Pastina

Finitura • Finish

Anticata (AK) | Lucida (LCD)

Antique (AK) | Polished (LCD)



ACS•809

MEZZO TORO | HALF TORUS

Formato • Format

33,3x33,3x1,6 cm

Materiale • Material

Graniglia

Finitura • Finish

Anticata (AK) | Lucida (LCD)

Antique (AK) | Polished (LCD)

160

ACCESSORI
ACCESSORIES



GRADINO UNICO ONE STEP



ACS•812

GRADINO UNICO

Formato • Format

< 130 cm

Materiale • Material

Graniglia

Finitura • Finish

Anticata (AK) | Lucida (LCD)

Antique (AK) | Polished (LCD)



162

ACCESSORI
ACCESSORIES

OLYMPIA

>>> MANUFATTI

La Linea Olympia offre manufatti per cucine e bagni che esprimono un perfetto equilibrio tra bellezza e la funzionalità.

The Olympia offers products for the kitchen and bathroom that express a perfect balance between beauty and practicality.

FOGAZZA

163

601 • CUPIDO

MATERIALE • MATERIAL
GRANIGLIA
FINITURA • FINISH
LUCIDA (LCD)



LAVELLO 2 POZZETTI AD INCASSO
BUILT IN DOUBLE SINK

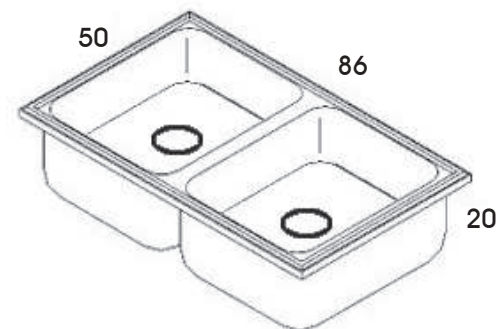

Ø FORO 90 mm | Ø SINK DRAIN 90 mm

602 • MIDA



LAVELLO 1 POZZETTI AD INCASSO
BUILT IN SINK

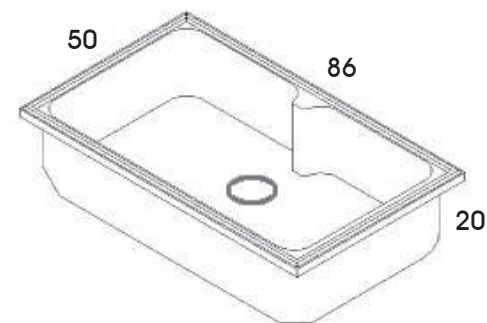

Ø FORO 90 mm | Ø SINK DRAIN 90 mm



603 • EFESTO

MATERIALE • MATERIAL
GRANIGLIA
FINITURA • FINISH
LUCIDA (LCD)



LAVELLO AD INCASSO CON GOCCIOLATOIO (DESTRO O SINISTRO)
BUILT IN SINK WITH LATERAL DRIP (LEFT OR RIGHT)

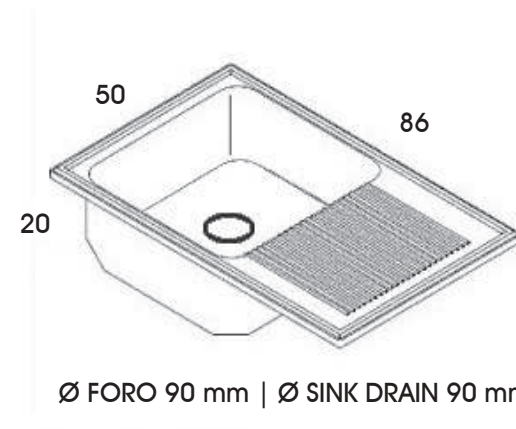

604 • SATURNO

LAVELLO DOPPIO AD INCASSO CON GOCCIOLATOIO (DESTRO O SINISTRO)
BUILT IN DOUBLE SINK WITH LATERAL DRIP (LEFT OR RIGHT)

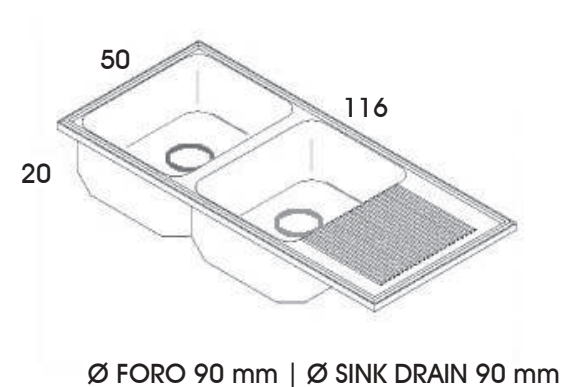

606 • ZEUS



MATERIALE • MATERIAL
GRANIGLIA
FINITURA • FINISH
LUCIDA (LCD)

POZZETTO AD INCASSO
BUILT IN SINK

Ø 47

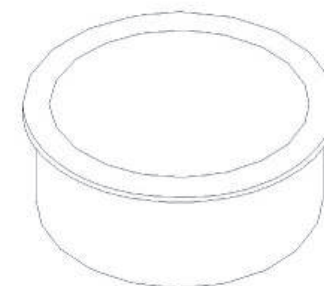

Ø FORO 90 mm | Ø SINK DRAIN 90 mm

612 • MORFEO



POZZETTO AD INCASSO
BUILT IN SINK

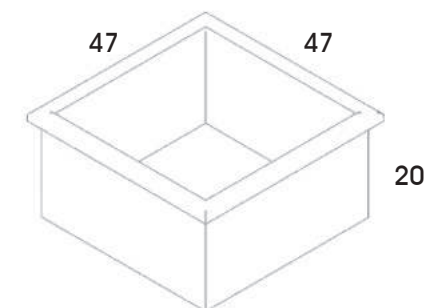

Ø FORO 90 mm | Ø SINK DRAIN 90 mm

■ ■ ■
701A • VENERE
701B



MATERIALE • MATERIAL
GRANIGLIA
FINITURA • FINISH
LUCIDA (LCD)

LAVELLO | CIOTOLA E LASTRA
SINK | BOWL AND SLAB

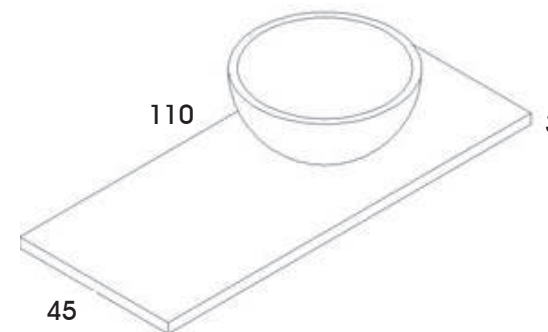

701 A SINK Ø 415 mm H 220 mm
701 B SINK Ø 550 mm H 250 mm
Ø FORO 50 mm | Ø SINK DRAIN 50 mm

■ ■ ■
704 • CERERE



LAVELLO
SINK

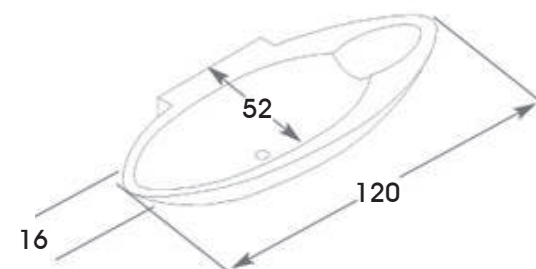

Ø FORO 30 mm | Ø SINK DRAIN 34 mm



706 • MINERVA

MATERIALE • MATERIAL
GRANIGLIA
FINITURA • FINISH
LUCIDA (LCD)



LAVELLO RETTANGOLARE D'APPOGGIO
SINK

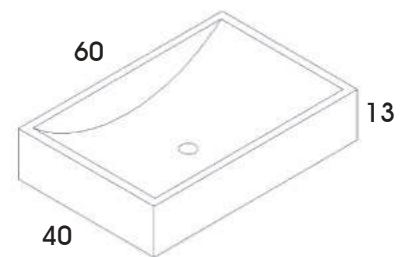

Ø FORO 35 mm | Ø SINK DRAIN 35 mm

707 • ORFEO

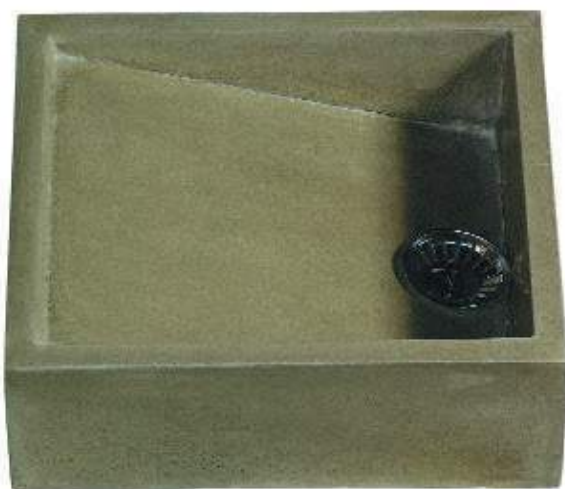

LAVELLO D'APPOGGIO QUADRATO
SINK

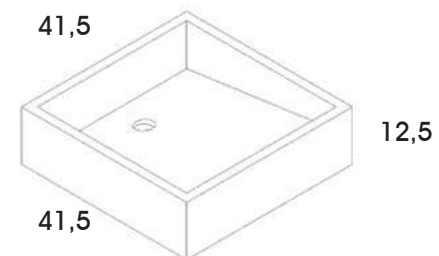

Ø FORO 35 mm | Ø SINK DRAIN 35 mm

170

OLYMPIA
bagno

715 • DECO

MATERIALE • MATERIAL
GRANIGLIA
FINITURA • FINISH
LUCIDA (LCD)



LAVELLO RETTANGOLARE D'APPOGGIO
SINK

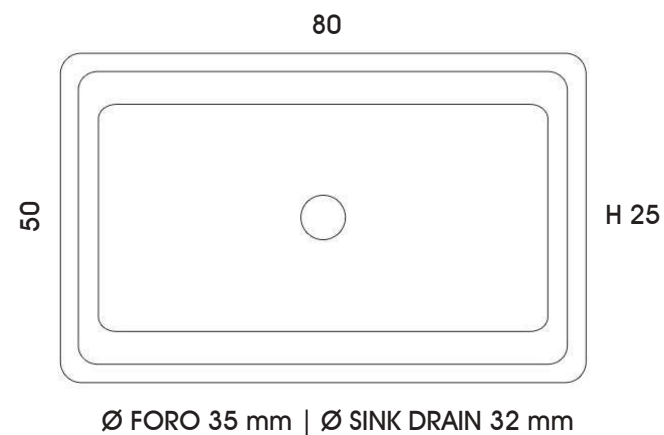

711 • HERMES



PIATTO DOCCIA ANGOLARE
CORNER SHOWER TRAY

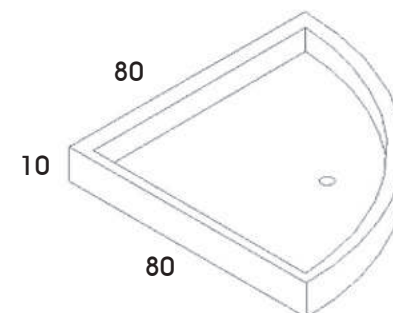

712 • IDRA

PIATTO DOCCIA RETTANGOLARE
RECTANGULAR SHOWER TRAY

MATERIALE • MATERIAL
GRANIGLIA
FINITURA • FINISH
LUCIDA (LCD)

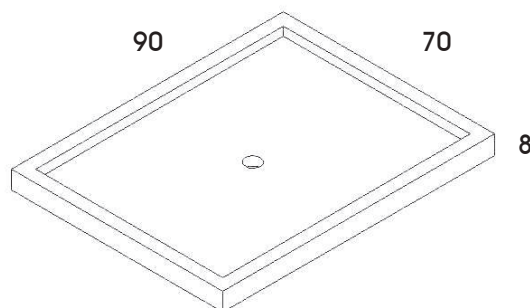

Ø FORO 55 mm | Ø SINK DRAIN 55 mm

713 • OLIMPO

PIATTO DOCCIA QUADRATO
SQUARE SHOWER TRAY

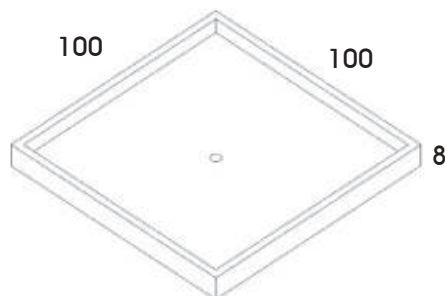

Ø FORO 55 mm | Ø SINK DRAIN 55 mm

900 • BOISERIE

LA STRA
SINGLE PLATE





PAVIMENTI FOGAZZA srl UNIPERSONALE

HEAD OFFICE

Via Ponte di Mare, 34
90123 Palermo, Italy
Tel +39 091 61 72 039
Fax +39 091 61 72 322

SEDE LEGALE

Via Federico II, 7
90011 Bagheria (PA), Italy
P.IVA 05856550826

SHOW ROOM

c/o Officine Milano
via Francesco De Sanctis, 30/34
20141 Milano, Italy
tel +39 345 6965299

info@fogazza.com
fogazza.com

PROGETTO GRAFICO E IMPAGINAZIONE

alkemica.it - Palermo

REALIZZAZIONE RENDERING 3D

Lelio Nuccio - Palermo

STAMPA

officinegrafiche.it - Palermo

II EDIZIONE

2019